

Mach3

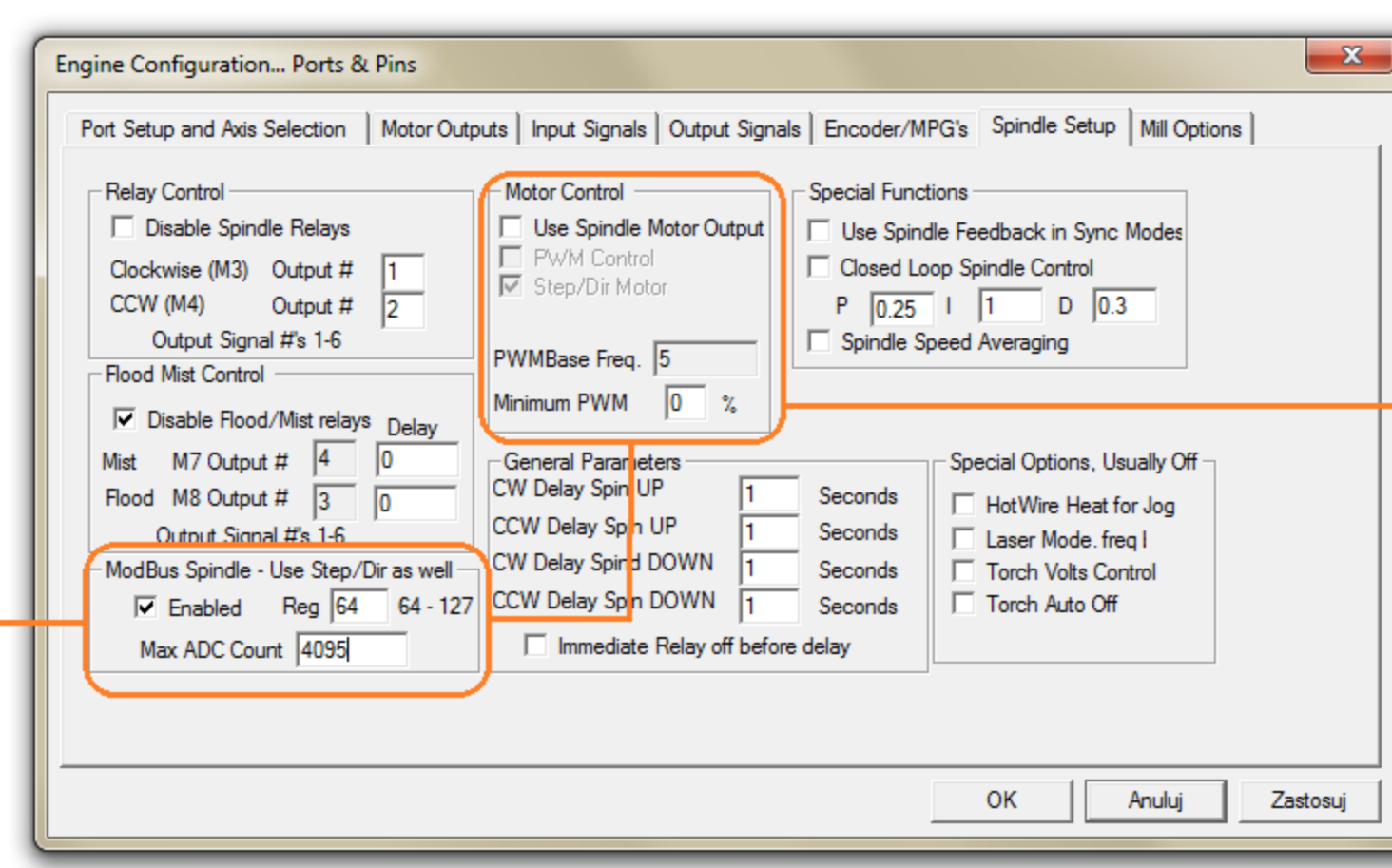
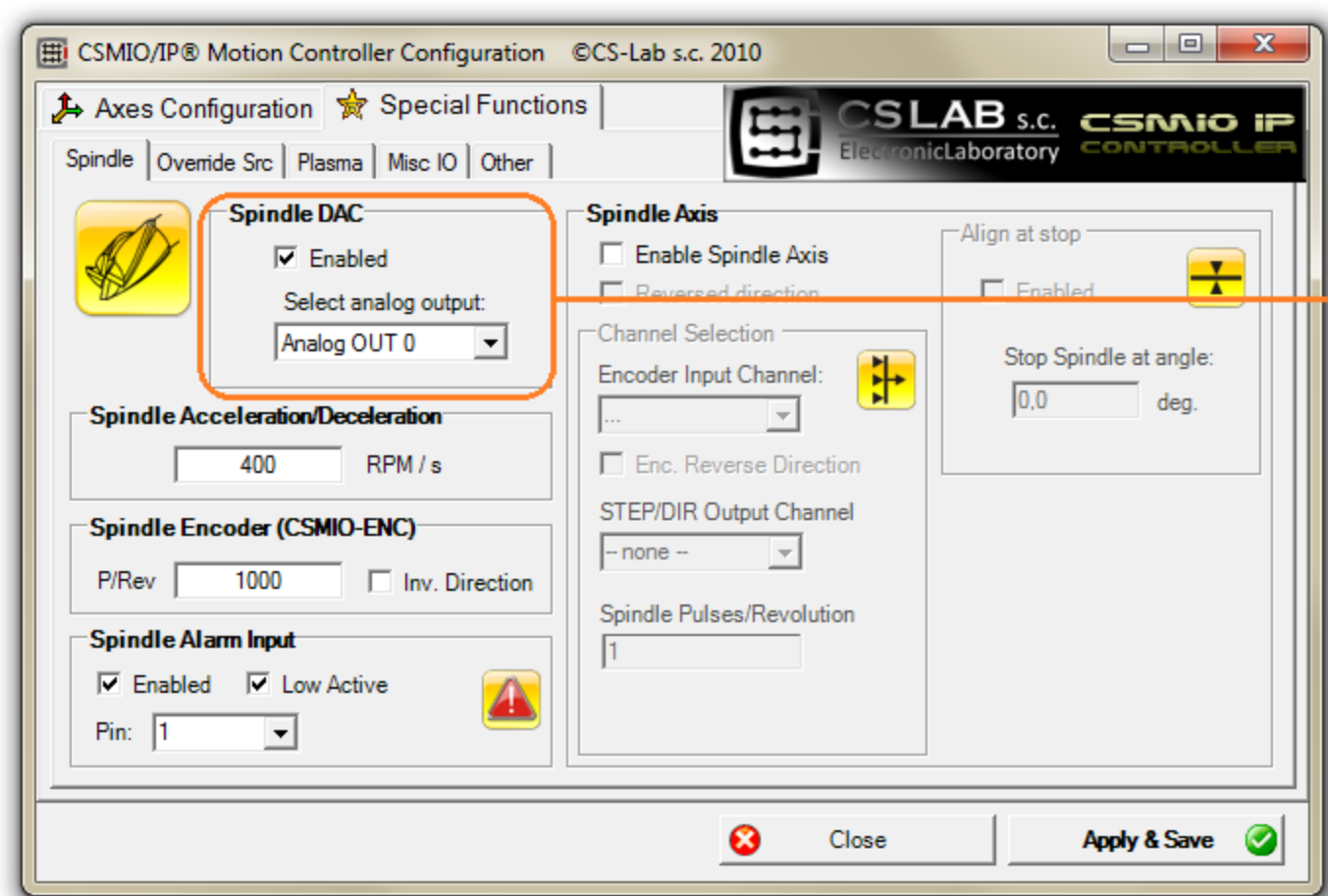
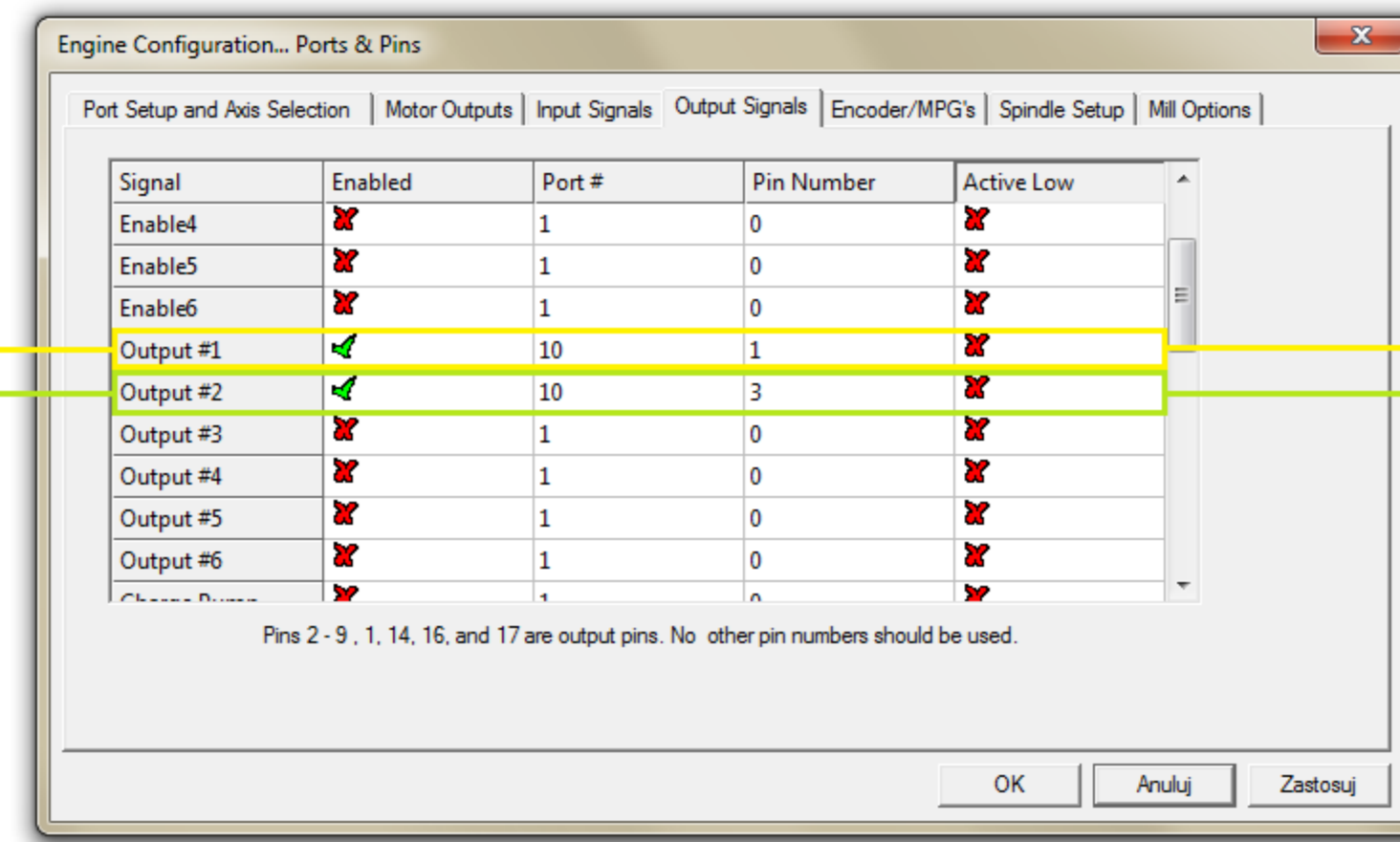
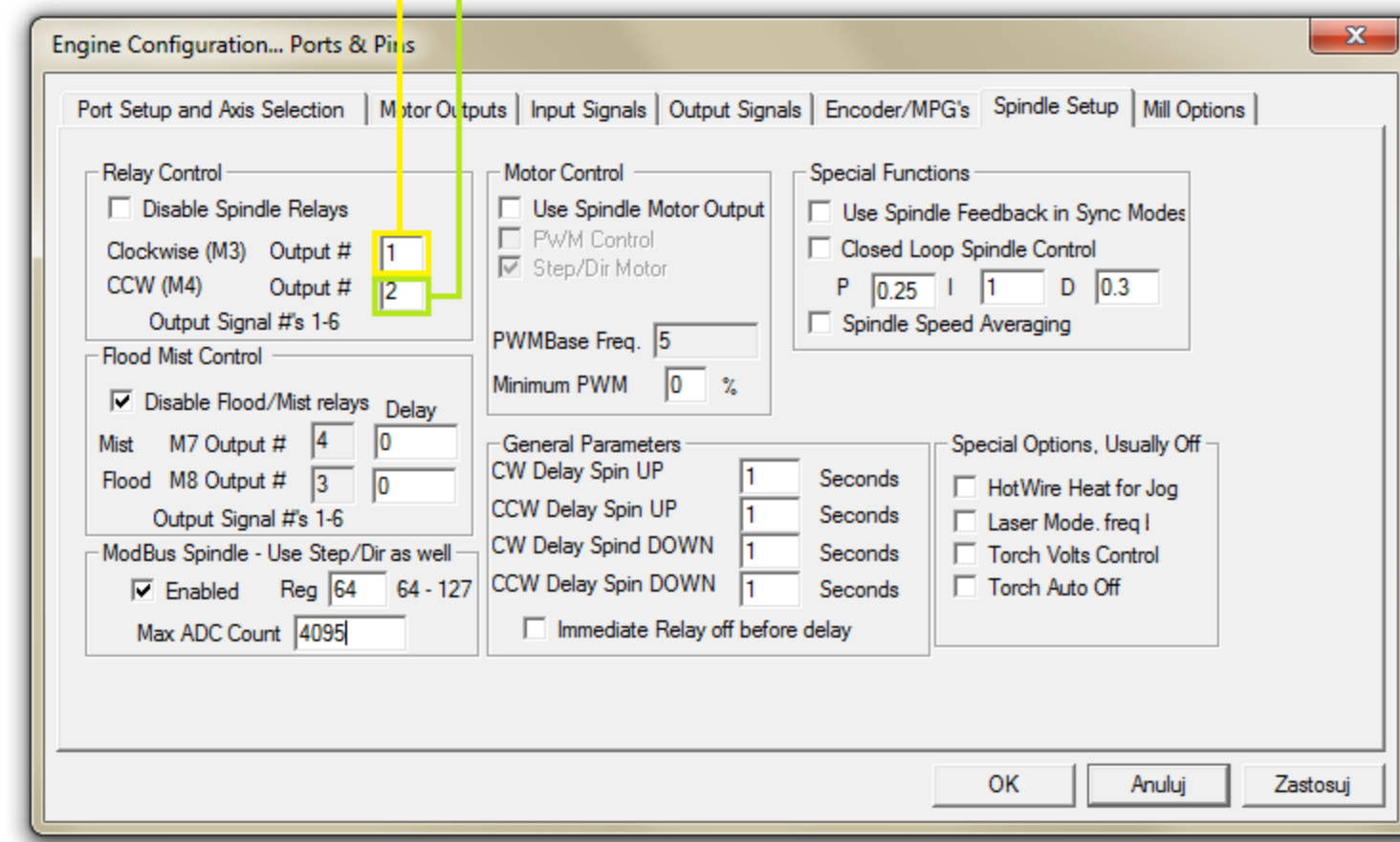
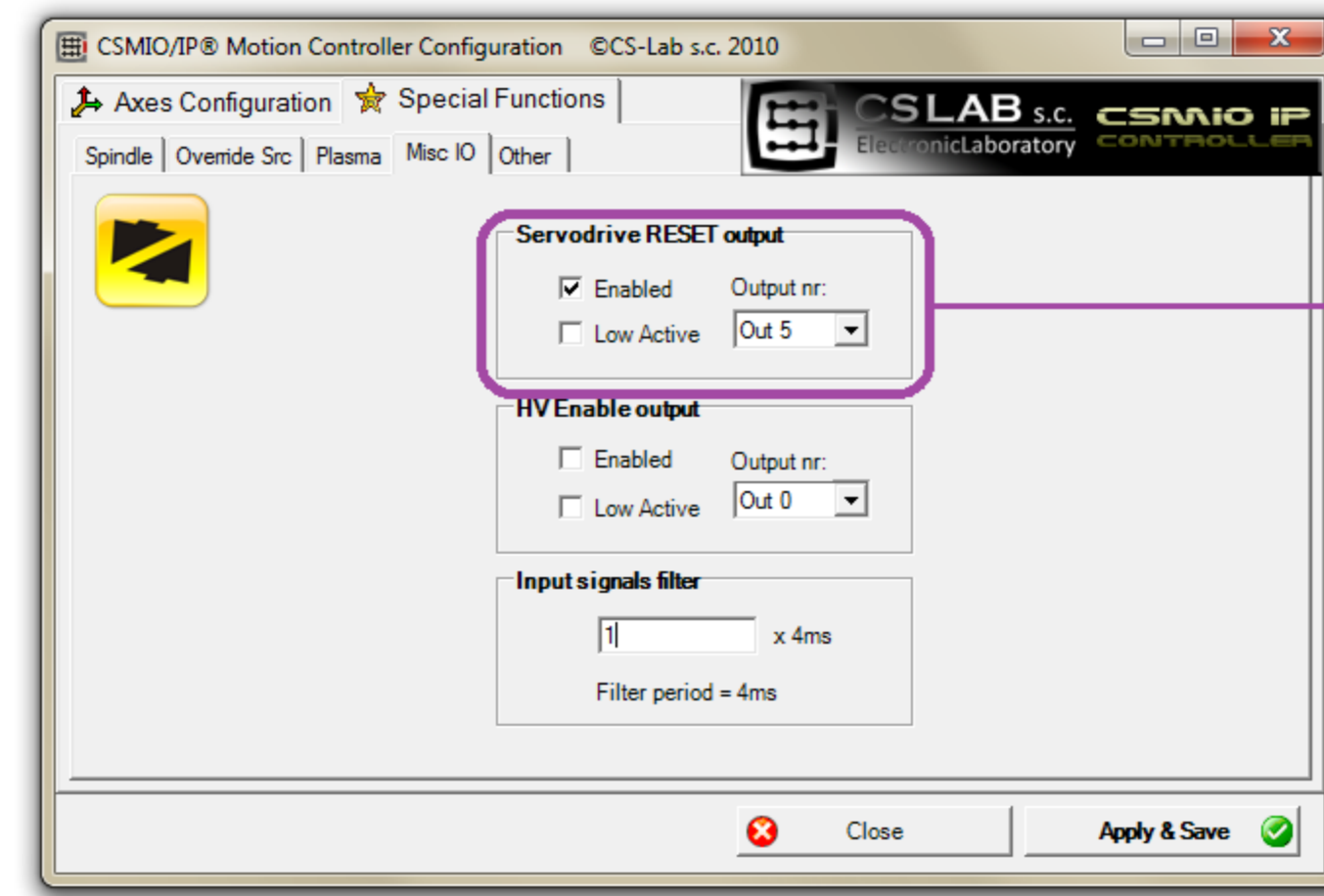
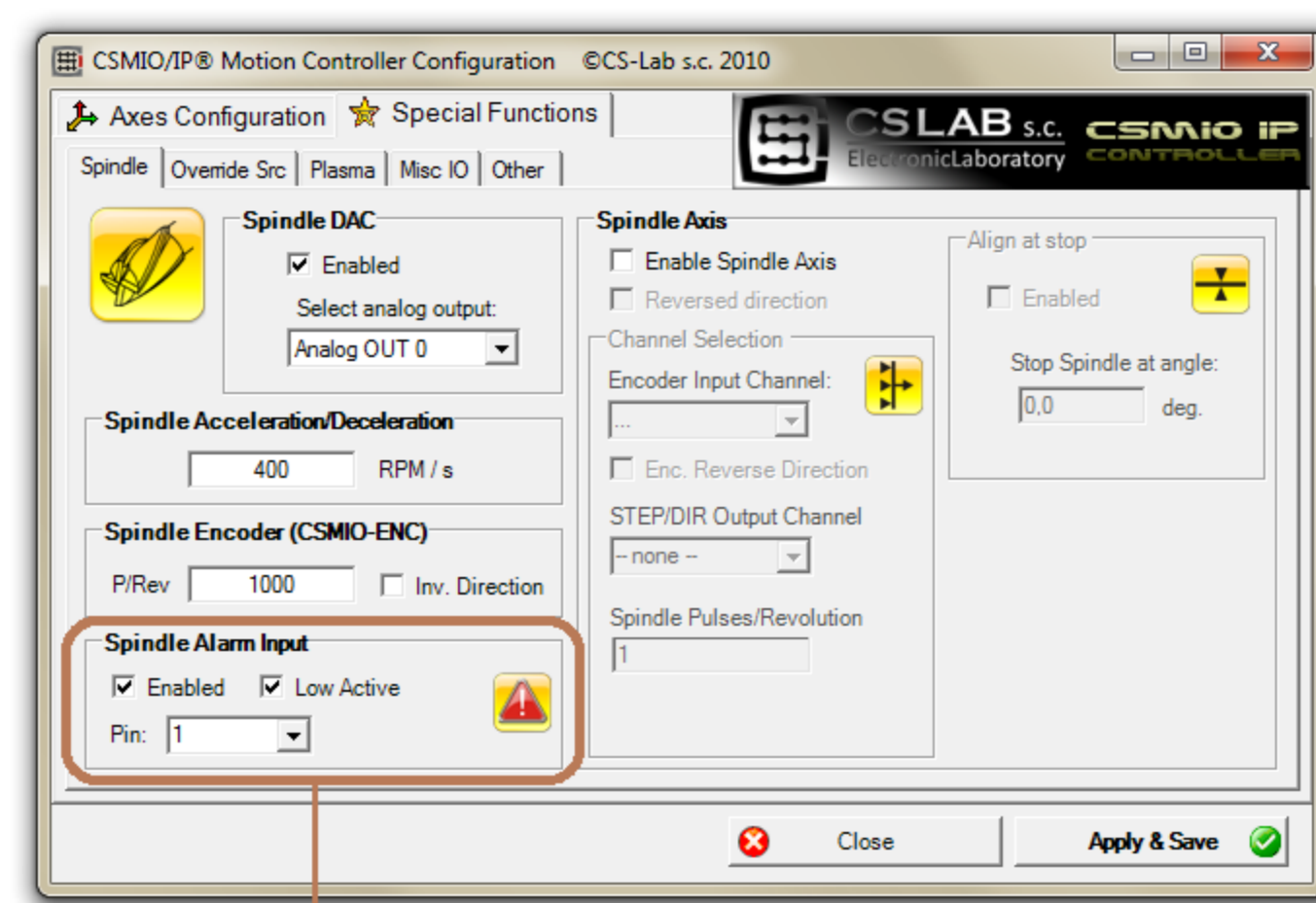

PIN number	Details
1	Input 0 (+)
2	Input 2 (+)
3	Input 4 (+)
4	Input 6 (+)
5	Inputs 0-7 (-)
6	Input 8 (-)
7	Input 9 (-)
8	Input 10 (-)
9	Input 11 (-)
10	Input 12 (-)
11	Input 13 (-)
12	Input 14 (-)
13	Input 15 (+)
14	Input 1 (+)
15	Input 3 (+)
16	Input 5 (+)
17	Input 7 (+)
18	Input 8 (+)
19	Input 9 (+)
20	Input 10 (+)
21	Input 11 (+)
22	Input 12 (+)
23	Input 13 (+)
24	Input 14 (+)
25	Input 15 (+)

PIN number	Details
1	24V power supply for 0-3 outputs
2	Output 0
3	Output 2
4	24V power supply for 4-7 outputs
5	Output 4
6	Output 6
7	24V power supply for 8-11 outputs
8	Output 8
9	Output 10
10	24V power supply for 12-15 outputs
11	Output 12
12	Output 14
13	GND (not in use)
14	Power supply 0V for 0-3 outputs
15	Output 1
16	Output 3
17	Power supply 0V for 4-7 outputs
18	Output 5
19	Output 7
20	Power supply 0V for 8-11 outputs
21	Output 9
22	Output 11
23	Power supply 0V for 12-15 outputs
24	Output 13
25	Output 15

PIN number	Details
1	Analog output 0
2	GND
3	Analog input 1
4	Analog input 2
5	10V (max. 50mA)
6	Analog output 1
7	Analog input 0
8	GND
9	Analog input 3

Pin number	Description
1	Power - 24V DC
2	GND
3	ground

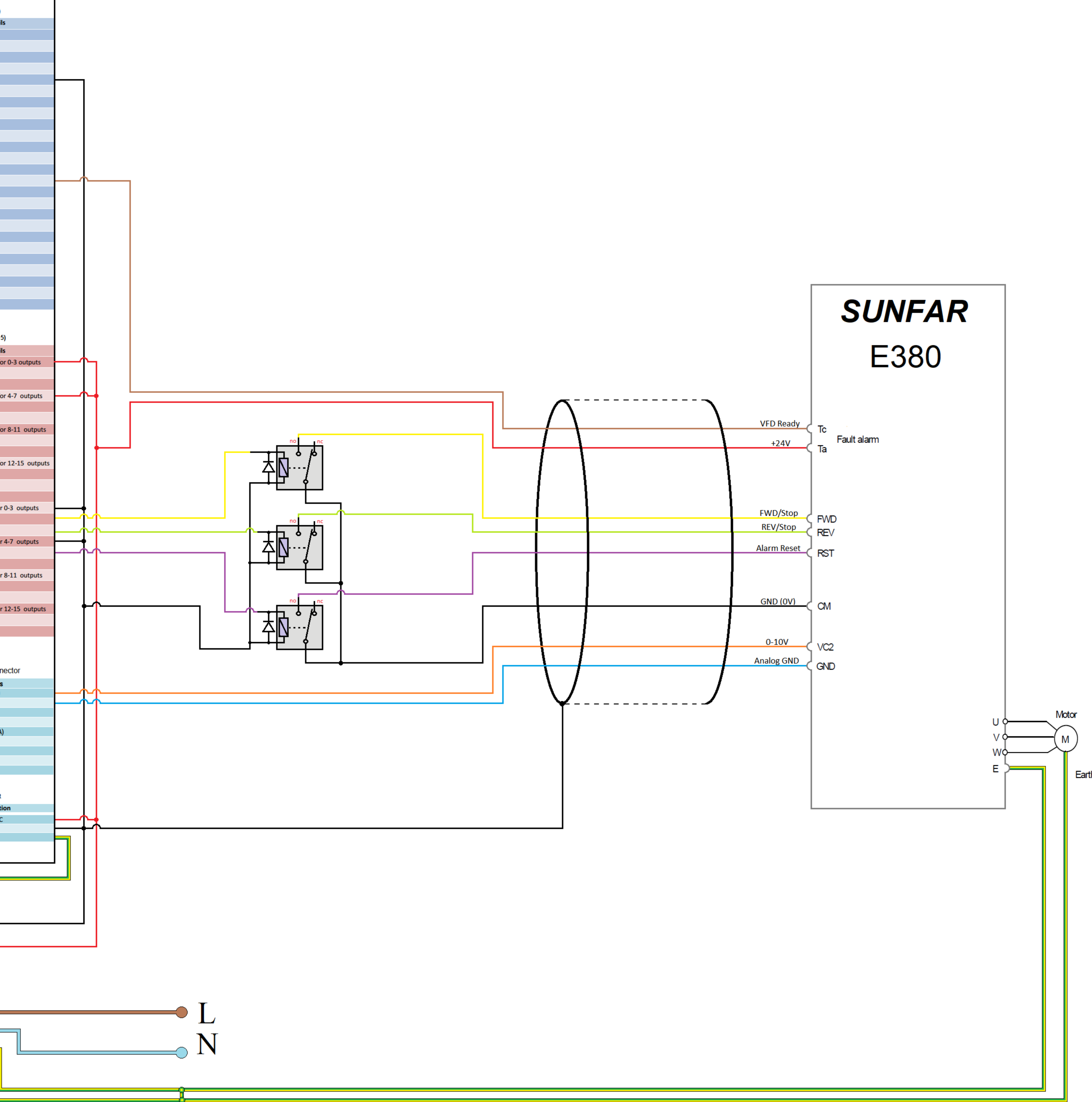
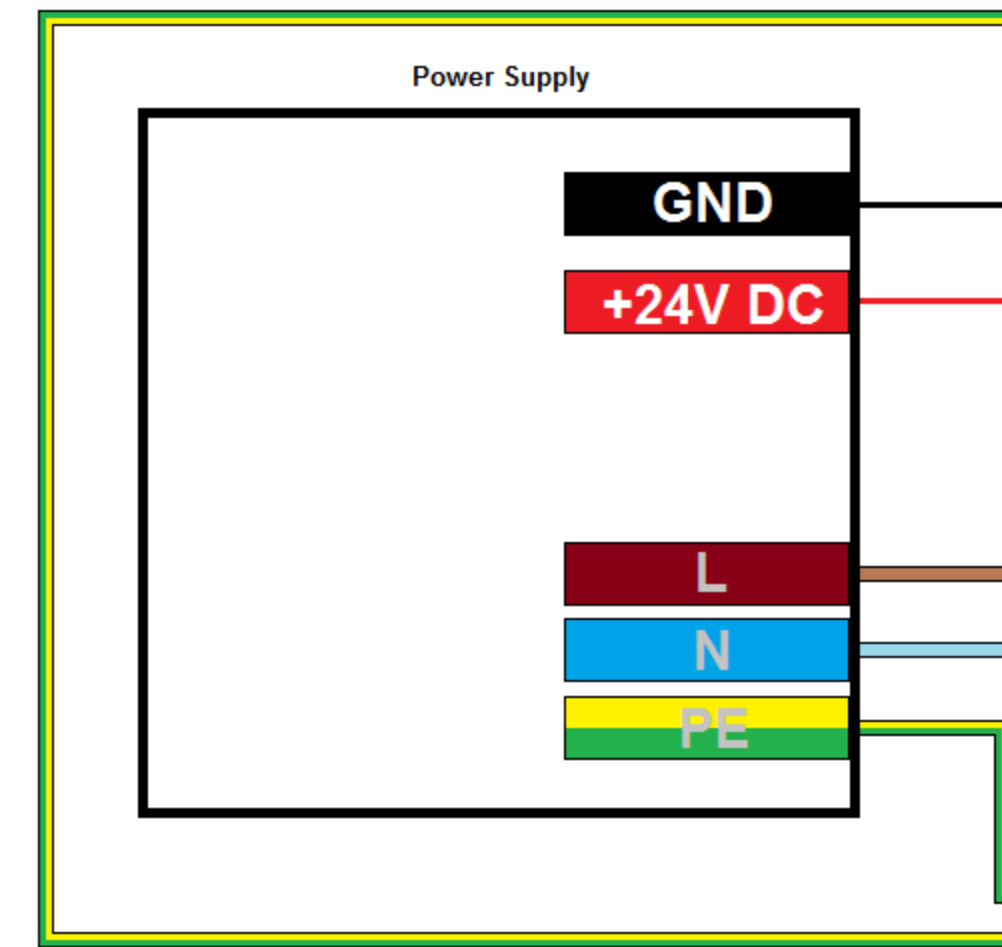

PE - Earth

Earth Bars
Listwa uziemiająca