



SHENZHEN SINOVO ELECTRIC TECHNOLOGY CO.,LTD
Add: 5th Floor, No. D Building, Huafeng International Robot
Industry Park, Xixiang Street, Hangcheng Road, Baoan
District, Shenzhen City
Tel: (0755)29784870
Fax: (0755)29784969
Tech support: 400-881-8689
<http://www.sinovo.cn>

Version: 2.0

SP200 Drive User Manual (Version: 2.0)

SINOVO

SINOVO
西林电气

SP200 SERIES PV PUMP CONTROLLER

User Manual



Preface

Thank you for purchasing the SP200 series PV Pump controller developed by our company.

This manual introduce how to use SP200 series in correct manner. Please read it carefully before application, operation, maintenance and inspection.

Please apply this series after fully understand the safety cautions of this products.

Unpacking Inspection Cautions:

1. Whether the product is damaged during shipping, whether the parts is damaging or falling, whether the main part is crashed.
2. Whether the nameplate of model and controller ratings are consistent with your order.

SINOVO is very strict in quality control in the producing and packing, in case any fault occurs, please contact us or your own supplier ASAP.

Note

- ✦ For the details of illustrating products, the diagram of this manual is sometimes in the status of removing the cover or safety cover. To use this product, please make sure install the cover or housing as required and operate in accordance with manual instructions.
- ✦ The diagrams in this manual is only for illustration, it may have slightly difference with the product that you ordered.
- ✦ This instructions are subject to change, without notice, due to product upgrade, specification as well as efforts to increase the accuracy and convenience of the manual.
- ✦ Please contact district agent or all SINOVO customer service center directly for the damaged or missing parts and need to order the Manuals.
- ✦ If you have any confusion when refering the manual during operation, please contact SINOVO Customer Service Center.
- ✦ Customer Service: 400-8818-689

Contents

Preface..... 01

Contents..... 02

Chapter 1 Safety and Cautions..... 05

 Safety Definition..... 05

 1.1 Safety Cautions..... 06

 1.2 Cautions..... 08

Chapter 2 Basic principle..... 11

 2.1 Basic principle..... 11

 2.2 Functions..... 13

Chapter 3 Product Information..... 15

 3.1 Inspection..... 16

 3.2 Instructions and Feature..... 16

 3.3 Protection function..... 16

 3.4 Naming rules..... 17

 3.5 SP200 PV Pump Controller input/output parameter..... 17

 3.6 Nameplate..... 21

 3.7 SP200 PV pump controller Size..... 21

Chapter 4 Mechanical and Electrical Installation..... 25

 4.1 Controller Installation and Operation Environment..... 26

 4.2 Controller Installation Spacing..... 27

 4.3 Install and Remove the Cover..... 27

 4.4 Wiring..... 28

Chapter 5 Operation..... 35

 5.1 Operation Panel Description..... 36

 5.2 Operation Procedure..... 38

 5.3 Commissioning Process..... 40

 5.4 Panel Displays Parameters in Running State..... 40

Chapter 6 Function Parameter Table.....41

- F00 Basic Function Group.....42
- F01 Startup and Stop Control.....42
- F02 Motor parameter.....42
- F03 Solar Water Pump Special Parameters.....42
- F05 Input Terminal Group.....43
- F07 HMI&Fault parameters.....43

Chapter 7 Troubleshooting.....47

- 7.1 Fault Instruction and Solution.....48
- 7.2 Common Faults and Solutions.....51
- 7.3 Controller Overcurrent, Overload Fault (OC1/2/3/OL1/2).....52

Chapter 8 Maintenance.....53

- 8.1 Controller.....54
- 8.2 Pump.....56
- 8.3 Solar Array.....56
- 8.2 Electric Wire and Cable.....56

Chapter 9 Spare AC power use.....57

Chapter

1

Safety and Cautions

Safety Definition

Read this manual carefully so that you have a thorough understanding.

Installation, commissioning or maintenance may be performed in conjunction with this chapter. Our company will assume no ability and responsibility for any injury or loss caused by improper operation.













Operations which are not performed comply with the requirements may cause severe hurt or even death.



Operations which are not performed comply with requirements may cause personal injury or property damage.

1.1 Safety Cautions

Use Stage	Safety Grade	Precautions
Before Installation	 Danger	<ul style="list-style-type: none"> ✦ Do not install the equipment if you find water seepage, component missing or damage upon unpacking. ✦ Do not install the equipment if the packing list does not conform to the product you received.
	 Danger	<ul style="list-style-type: none"> ✦ Handle the equipment with care during transportation to prevent damage to the equipment. ✦ Do not use the equipment if any component is damaged or missing. Failure to comply will result in personal injury. ✦ Do not touch the components with your hands. Failure to comply will result in static electricity damage.
During Installation	 Danger	<ul style="list-style-type: none"> ✦ Install the equipment on incombustible objects such as metal, and keep it away from combustible materials. Failures to comply may result in a fire. ✦ Do not loosen the fixed screws of the components, especially the screws with red marks.
	 Note	<ul style="list-style-type: none"> ✦ Do not drop wire end or screw into the controller. Failure it will result in damage to the controller. ✦ Install the controller in places free of vibration and direct sunlight. ✦ When two controller are laid in the same cabinet ,arrange the installation positions properly to ensure the cooling effect.
At wiring	 Danger	<ul style="list-style-type: none"> ✦ A circuit breaker must be used to isolate the power supply and the controller. Failure to comply may result a fire. ✦ Ensure that the power supply is cut off before wiring. Failure to comply may result in electric shock. ✦ Never connect the power cables to the output terminals(U,V,W) of the controller. Pay attention to the marks of the wiring terminals and ensure correct wiring. Failure to comply may result in damage to the controller. ✦ Ensure that the main cable line comply with the standard, the line meets the EMC requirements and the area safety standard. Failure to comply may result in risk or accident. ✦ Never connect the power cables the braking resistor between the DC bus terminals P+, P-. Failure to comply may result in a fire.

Use Stage	Safety Grade	Precautions
At wiring	 Danger	<ul style="list-style-type: none"> ✦ Use a shielded cable for the encoder, and ensure that the shielding layer is reliably grounded.
Before Power-on	 Danger	<ul style="list-style-type: none"> ✦ Please confirm the peripheral equipment and cable converter is configured in this manual of the recommended model, all the configuration line in accordance with the connection method of the manual provides the correct wiring. Failure to comply will result in accidents. ✦ Check that the voltage class of the power supply is consistent with the rated voltage class of the controller.
After Power-on	 Danger	<ul style="list-style-type: none"> ✦ Do not open the controller's cover after power-on. Failure to comply may result in electric shock. ✦ Do not touch the operation of controller during the hands is wet. Failure to comply will result in accident. ✦ Do not touch any I/O terminal of the controller. Failure to comply may result in electric shock. ✦ Do not change the default settings of the controller. Failure to comply will result in damage to the controller. ✦ Do not touch the rotating part of the motor during the motor auto-tuning or running. Failure to comply will result in accident.
During Operation	 Danger	<ul style="list-style-type: none"> ✦ Signal detection must be performed only by qualified personnel during operation. Failure to comply will result in personal injury or damage to the controller. ✦ Do not touch the fan or the discharging resistor to check the temperature. Failure to comply will result in personal burnt.
	 Danger	<ul style="list-style-type: none"> ✦ Avoid objects falling into the controller when it is running. Failure to comply will result in damage to the controller. ✦ Do not start or stop the controller by turning the contactor ON/OFF. Failure to comply will result in damage to the controller.
After Power-on	 Danger	<ul style="list-style-type: none"> ✦ Do not repair or maintain the controller at power-on. Failure to comply will result in electric shock. ✦ Ensure that the controller is disconnected from all power suppliers before starting repair or maintenance on the controller. ✦ Repair or maintenance of the controller may be performed only by qualified personnel. Failure to comply will result in personal injury or damage to the controller.

Use Stage	Safety Grade	Precautions
After Power-on	 Danger	✦ Set and check the parameters again after the controller is replaced.

1.2 Cautions

1.2.1 Motor Insulation Test

Perform the insulation test when the motor is used for the first time, or when it is reused after being stored for a long time, or in a regular check-up, in order to prevent the poor insulation of motor windings from damaging the controller during the insulation test. A 500-V mega-Ohm meter is recommended for the test. The insulation resistance must not be less than 5 MΩ.

1.2.2 Thermal Protection of Motort

If the selected controller does not match the rated capacity of the motor , especially when the rated power of the controller is higher than that of the motor, adjust the parameters for motor protection in the controller or to install thermal relay to protect the motor .

1.2.3 Running Above Rated Frequency

The controller provides frequency output of 0 to 600.00Hz. If the controller is required to run at over 50Hz, please consider the capacity of the machine.

1.2.4 Vibration of mechanical device

The controller may encounter the mechanical resonance point at some output frequenc-ies, which can be avoided by setting the skip frequency. If the operating frequency of the customer coincide with the resonant frequency please modify the operating frequency or change the inherent resonance frequency of the mechanical system.

1.2.5 Motor heat and noise

The output of the controller is pulse width modulation (PWM) wave with certain harmonic frequencies, and therefore, the motor temperature, noise, and vibration are slightly greater than those when the controller runs at power frequency (50 Hz).

1.2.6 Voltage-sensitive device or capacitor on output side of the controller

Do not install the capacitor for improving power factor or lightning protection voltage-sensitive resistor on the output side of the controller because the output of the controller is PWM wave. Otherwise, the controller may suffer transient overcurrent or even bedamaged.

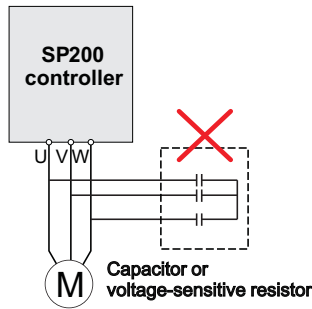

1.2.7 Contactor at the I/O terminal of the controller

When a contactor is installed between the input side of the controller and the power supply, the controller must not be started or stopped by switching the contactor on or off. If the controller has to be operated by the contactor, ensure that the time interval between switching is at least one hour since frequent charge and discharge will shorten the service life of the capacitor inside the controller.

When a contactor is installed between the output side of the controller and the motor, do not turn off the contactor when the controller is active. Otherwise, modules inside the controller may be damaged.

1.2.8 The Use Occasion of the External Voltage Out of Rated Voltage Range

The controller must not be used outside the allowable voltage range specified in this manual. Otherwise, the controller's components may be damaged. If required, use a corresponding voltage step-up or step-down device.

1.2.9 Change Three Phase Input into Two Phase Input

It is not allowed to change the three phase controller into two phase one. Otherwise, it may cause it may cause fault or damage the controller.

1.2.10 The Protection of the Lighting Impulse

Although the controller has equipped with lightning overvoltage, overcurrent device, which has a certain protection function for the induction lightning. For the lightning prone areas, the user is necessary to install lightning protection device at the front of the controller, which will benefit to the service life of the transducer.

1.2.11 Altitude and Derating

In places where the altitude is above 1000m and the cooling effect reduces due to thin air it is necessary to de-rate the controller. Contact Our company for technical support.

1.2.12 Some Special Usages

If writing that is not described in this manual, such as common DC bus is applied, contact the agent or Our company for technical support.

1.2.13 The Cautious of the controller Disposal

The electrolytic capacitors on the main circuits and PCB may explore when they are burnt. Poisonous gas is generated when the plastic parts are burn. Treat them as ordinary industrial refer to relevant national laws and regulations.

1.2.14 Adaptable Motor

1. The standard parameters of the adaptable motor is adaptable four-squirrel-cage asynchronous induction motor or PMSM. For other types of motor, select a proper controller according to the rated motor current.
2. The cooling fan and rotor shaft of general controller are coaxial, which results in reduced cooling effect when the rotational speed declines. If variable speed is required, add a more powerful fan or replace.
3. The standard parameters of the adaptable motor have been configured inside the controller. It is still necessary to perform motor auto-tuning or modify the default values based on actual conditions. Otherwise, the running result and protection performance will be affected.
4. The controller may alarm or even be damaged when short-circuit exists on cables or inside the motor. Therefore, perform insulation short-circuit test when the motor and cables are newly installed or during routine maintenance. During the test, make sure that the controller is disconnected from the tested parts.



Chapter 2

Basic principle

2.1 Basic principle

SP 200 solar pumping system can provide water for remote areas lacking of electricity or places where the electricity supply is unstable. PV pump controller can convert the DC power from solar panels to AC power so to drive various kinds of pumps. System enables continuously pumping when in good weather. System is not equipped with storage battery devices, it is suggested that pumping the water to conservation pool for future use. Water source could come from river, lake, well, or other natural water source or special source. System enables application of floating switch in the conservation pool or water tower to control the operation of pumps. Low water level probes can be installed in the well to detect the water level of the well in order to stop the pumps when the well in low water level. Diagram 1 is a typical SP200 PV pumping system. The main parts and components of this system is after diagram 1.

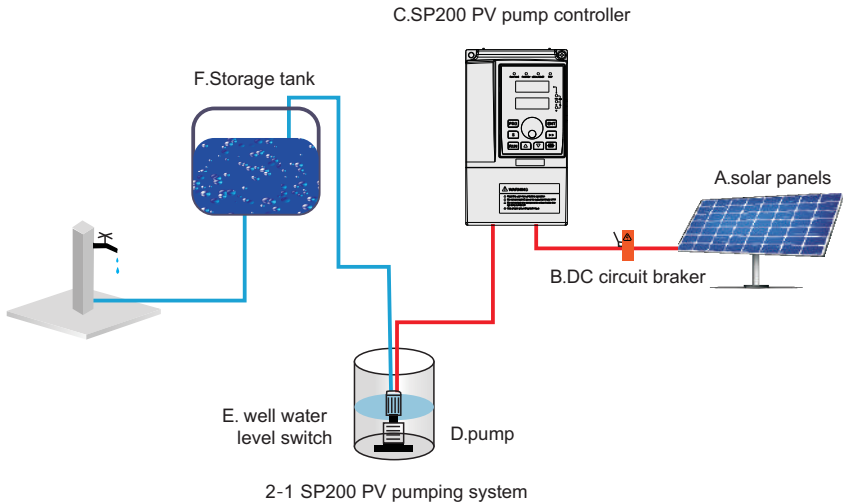

SP200 PV pumping system is composed of following parts:

- A: Solar panels
- B: DC circuit breaker or disconnector
- C: SP200 PV pump controller
- D: Pump
- E: well water level switch(optional)
- F: water tower water level switch(optional)

SP200 PV pump controller can start the pump softly and is consistent with the electricity coming from the changes providing by solar panels. The advantage of soft starting is avoid surge or power surges when the pump or motor are in the process of starting,whi-ch reduce the loss of motor and pumping system.

Requirements of pump check valve:

Note: To ensure the best reliability of the system and water supply, check valves is required to be installed in the output pipe. The first check valves must be installed in the outlet of pumps, the rest check valves should be installed in the vertical direction of the pipes of every 30 meters(100 feet) behind the pump.

2.2 Functions

System diagnostics

SP200 PV pump controller continuously monitor the system performance and can detect a variety of abnormal circumstance. In most cases, controller provide compensations as required to keep the non-stop operation of the system. If there is a damage, controller will protect the system and display fault state. If possible, controller will restart after the fault status is gone. Fault codes and correction information please refer to the chapter of Detecting and troubleshooting.

Motor soft-starter

Generally speaking, SP200pv pump controller will operate when there is water requirement or electricity is available. Everytime SP200 PV Pump Controller detect the water requirement, the rotating speed is always improved slowly and at the same time add motor voltage gradually. Compared to traditional water supply system, solar pumping sytem's motor temperature and starting current is much lower. Controller with soft starting function has no damage to the motor.

Overheating monitoring

SP200 PV pump controller can run at full power when the ambient temperature reaches 45°C. For temperature above 45°C, controller will keep on running by reducing output power. When the controller temperature cooled to safety point, it will run at full power output.

Water level float switch

SP200 PV pump controller can connect 2 water level detecting switch to detect pump running by remote control. Water level switch is optional to the controller, it is not required.

SP200 PV pump controller's input power terminals can be switched to spare AC power supply manually.

Spare AC power supply switch

Note: Based on different models, SP200 input power could be 220v AC single power, or 380V AC 3 phase power. For more information, please contact SINOVO or certified agent. When the system is running by spare AC power, please check the DC power every 30 mins. If the AC power is applicable, then stop the controller and switch to the AC power and try to run the pump at the AC power driving way.

Note:

DC circuit switching and generator power switch installation are required and both switches should be mutually locked to prevent they were connected at the same time which lead to the solar panels and generator connect SP200 controller simultaneously. Please check if the design meets electrical specifications of relative country and area.



Chapter 3

Product Information

SP200 PV pump controller is adjustable speed motor controller designed in accordance with any IEC standard 3 phase asynchronous motor. SP200 PV pumping system convert the high voltage DC power of solar array into AC power to drive an standard 3 phase asynchronous motor thus provide water for remote areas. When the solar power is not enough, controller can be switched manually to spare single or 3 phase AC power, such as generator. This controller is functioned with fault detection, motor soft-starting, and speed control.SP200 PV Pump Controller is designed with the function of plug-and-play and easy to install.SP200 PV Pump Controller is a product of stable performance and high standard. In weak light condition, controller will try to drive pump for water lifting, but if the light is becoming weaker, then controller will reduce the speed of pump to protect the system components from damaged and shut down during some extreme circumstances.When the special circumstances is gone, controller will restart driving the pump.

3.1 Inspection

Before using, please check the SP200 PV pump controller components firstly. Please make sure the components serial number is correct and if the product is damaged during shipping.

3.2 Instructions and Feature

SP200 PV Pump Controller monitor the system performance continuously and with integrated protection of multi-function pump system. When fault occurs, SP200 PV Pump Controller will display the type of faults by LED screen in the front of the controller and will automatically reset routine fault.

Internal Diagnostics allows lower input voltage.

Whenever possible, the controller will maximize the use of the solar array output to drive the pump.

To provide users with an easy interface, enhanced configurability and realize remote monitoring system.

3.3 Protection Function

Electronic monitoring enables the controller to monitor systems and automatically shut down in following circumstances:

1. Wells is short of water- Low liquid level switches;
2. Pump locked rotor overload protection;
3. High voltage surge;
4. Low output voltage;
5. Motor lack phase;
6. Short circuit;
7. Over heating.

Note:

the controller protect the motor by limiting load running when the motor current exceeds the rated current at the time of low water leve.The controller does not provide high motor temperature detection.

3.4 Naming Rules

In the model code contains the product information Users can find the code from the transducer and simple nameplate.



Field	Mark	Content
controller series	①	Solar water pump controller
Series number	②	Series second generation
Voltage Level	③	2: Three-phase 220V 4: Three-phase 380V
voltage range	④	S: Rated voltage 310VDC, Recommended voltage range (MTTP) 180VDC~360VDC T: Rated voltage 540VDC, Recommended voltage range (MTTP) 500VDC~600VDC
Pump rated power	⑤	2.2: 2.2KW

Figure 3-1 Name Designation Rules

3.5 SP200 PV Pump Controller input/output parameter

SP200-2SXXX

Model	SP200-2S-0.7	SP200-2S-1.5	SP200-2S-2.2
PV array input parameter			
Max input voltage (V)	DC 450V		
Min input voltage (V)	DC 180V		
Recommended voltage(mpp)	DC 280~360V		
Recommended PV power(Kw)	0.9~1.2	1.8~2.4	2.7~3.5
Spare AC generator			
Input voltage (V)	Single phase AC 200-240(±10%)		
Max current(A)	8.2	14	23
Generator capacity(kVA)	1.5	3	4
Output parameter			
Rated output voltage	3-phase AC 200-240V		
Max current(A)	4.7	7.5	10
Rated output power(kW)	0.75	1.5	2.2
Output frequency	0~50Hz/60Hz		

SP200-4TXXX Input/output parameter

Model	SP200-4T-2.2	SP200-4T-3.7	SP200-4T-5.5	SP200-4T-7.5
PV array input parameter				
Max input voltage (V)	DC 800V			
Min input voltage (V)	DC 350V			
Recommended voltage(mpp)	DC 500~600V			
Recommended PV power(Kw)	2.7~3.5	4.8~6.4	6.6~8.8	9~12
Spare AC generator				
Input voltage (V)	3-phase AC 380/400/415/440V(+15%)			
Max current(A)	5.8	10.5	14.6	20.5
Generator capacity(kVA)	4	5.9	8.9	11
Output parameter				
Rated output voltage	3-phase AC 380/400/415/440V(+15%)			
Max current(A)	5.1	9	13	17
Rated output power(kW)	2.2	3.7	5.5	7.5
Output frequency	0~50Hz/60Hz			

Model	SP200-4T-11	SP200-4T-15	SP200-4T-18.5	SP200-4T-22
PV array input parameter				
Max input voltage (V)	DC 800V			
Min input voltage (V)	DC 350V			
Recommended voltage(mpp)	DC 500~600V			
Recommended PV power(Kw)	13.2~17.6	18~24	22.2~29.6	26.4~35.2
Spare AC generator				
Input voltage (V)	3-phase AC 380/400/415/440V(+15%)			
Max current(A)	26	35	38.5	46.5
Generator capacity(kVA)	17	21	24	30
Output parameter				
Rated output voltage	3-phase AC 380/400/415/440V(+15%)			
Max current(A)	25	32	37	45
Rated output power(kW)	11	15	18.5	22
Output frequency	0~50Hz/60Hz			

Model	SP200-4T-30	SP200-4T-37	SP200-4T-45	SP200-4T-55
PV array input parameter				
Max input voltage (V)	DC 800V			
Min input voltage (V)	DC 350V			
Recommended voltage (mpp)	DC 500~600V			
Recommended PV power(Kw)	36~48	44~59.2	54~72	66~88
Spare AC generator				
Input voltage (V)	3-phase AC 380/400/415/440V(+15%)			
Max current(A)	62	76	92	113
Generator capacity(kVA)	40	57	69	85
Output parameter				
Rated output voltage	3-phase AC 380/400/415/440V(+15%)			
Max current(A)	60	75	91	112
Rated output power(kW)	30	37	45	55
Output frequency	0~50Hz/60Hz			

Model	SP200-4T-75	SP200-4T-90	SP200-4T-110	SP200-4T-132
PV array input parameter				
Max input voltage (V)	DC 800V			
Min input voltage (V)	DC 350V			
Recommended voltage (mpp)	DC 500~600V			
Recommended PV power(Kw)	90~120	44~59.2	132~176	159~211
Spare AC generator				
Input voltage (V)	3-phase AC 380/400/415/440V(+15%)			
Max current(A)	157	180	214	256
Generator capacity(kVA)	114	134	160	192
Output parameter				
Rated output voltage	3-phase AC 380/400/415/440V(+15%)			
Max current(A)	150	176	210	253
Rated output power(kW)	75	90	110	132
Output frequency	0~50Hz/60Hz			

Model	SP200-4T-160	SP200-4T-200	SP200-4T-220	SP200-4T-250
PV array input parameter				
Max input voltage (V)	DC 800V			
Min input voltage (V)	DC 350V			
Recommended voltage (mpp)	DC 500~600V			
Recommended PV power(Kw)	192~256	240~320	264~352	300~400
Spare AC generator				
Input voltage (V)	3-phase AC 380/400/415/440V(+15%)			
Max current(A)	307	385	430	468
Generator capacity(kVA)	231	250	280	355
Output parameter				
Rated output voltage	3-phase AC 380/400/415/440V(+15%)			
Max current(A)	304	377	426	465
Rated output power(kW)	160	200	220	250
Output frequency	0~50Hz/60Hz			

Model	SP200-4T-280	SP200-4T-315	SP200-4T-355	SP200-4T-400
PV array input parameter				
Max input voltage (V)	DC 800V			
Min input voltage (V)	DC 350V			
Recommended voltage (mpp)	DC 500~600V			
Recommended PV power(Kw)	192~256	378~504	426~568	480~640
Spare AC generator				
Input voltage (V)	3-phase AC 380/400/415/440V(+15%)			
Max current(A)	525	590	665	785
Generator capacity(kVA)	396	445	500	565
Output parameter				
Rated output voltage	3-phase AC 380/400/415/440V(+15%)			
Max current(A)	520	585	650	725
Rated output power(kW)	280	315	355	400
Output frequency	0~50Hz/60Hz			

Note:

According to the different illumination in different regions, recommended PV array power is 1.2 to 1.6 times of the controller power.

3.6 Nameplate

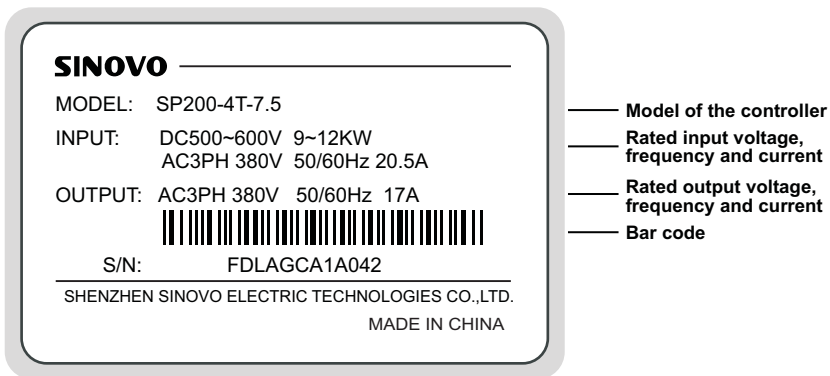
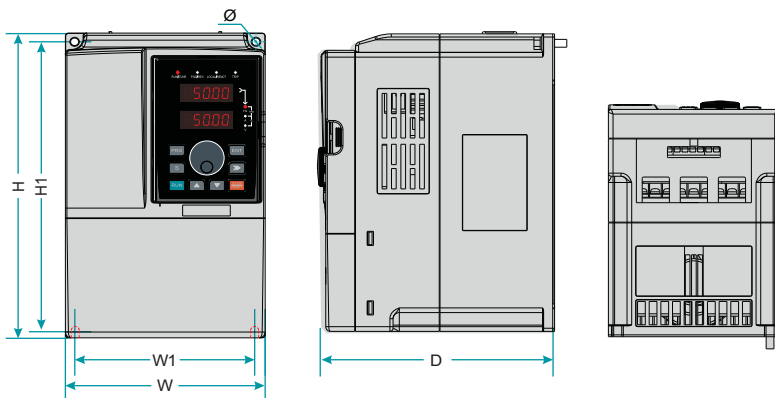

Figure 3-2 Name Designation Rules

3.7 SP200 PV Pump Controller Size



7.5KW Less than 7.5KW Controller installation dimensions and installation size

3.7.1 Installation Hole Size

Controller Model	H(mm)	W(mm)	D(mm)	H1(mm)	W1(mm)	Diameter (mm)	GW(kg)
SP200-2S-0.7	190	110	150	178	98	Ø5	2.4
SP200-2S-1.5							
SP200-2S-2.2							
SP200-2T-0.7	190	110	150	178	98	Ø5	2.4
SP200-2T-1.5							
SP200-2T-2.2							
SP200-4T-0.7	190	110	150	178	98	Ø5	2.4
SP200-4T-1.5							
SP200-4T-2.2							
SP200-4T-4.0	210	130	160	198	118	Ø5	3.5
SP200-4T-5.5	250	155	176	236	141	Ø5	4.5
SP200-4T-7.5							
SP200-4T-11	285	170	162	270	135	Ø6	5.1
SP200-4T-15	332	220	214	318	140	Ø7	9.3
SP200-4T-18.5							
SP200-4T-22	387	250	220	373	150		14
SP200-4T-30							19
SP200-4T-37	440	270	252	426	180		25
SP200-4T-45							
SP200-4T-55	550	300	258	534	200	Ø9	32
SP200-4T-75	650	370	282	625	250		52
SP200-4T-90							55
SP200-4T-110							58
SP200-4T-132	880	485	310	860	320	Ø13	99
SP200-4T-160							
SP200-4T-185							
SP200-4T-200	1250	500	400	1000	440	Ø13	167
SP200-4T-220							
SP200-4T-250							
SP200-4T-280	1350	650	400	1105	513	Ø13	206
SP200-4T-315							
SP200-4T-350							
SP200-4T-400	1810	850	405	1410	513	Ø13	415
SP200-4T-450							
SP200-4T-500							

3.7.2 External Keypad Installation Dimensions

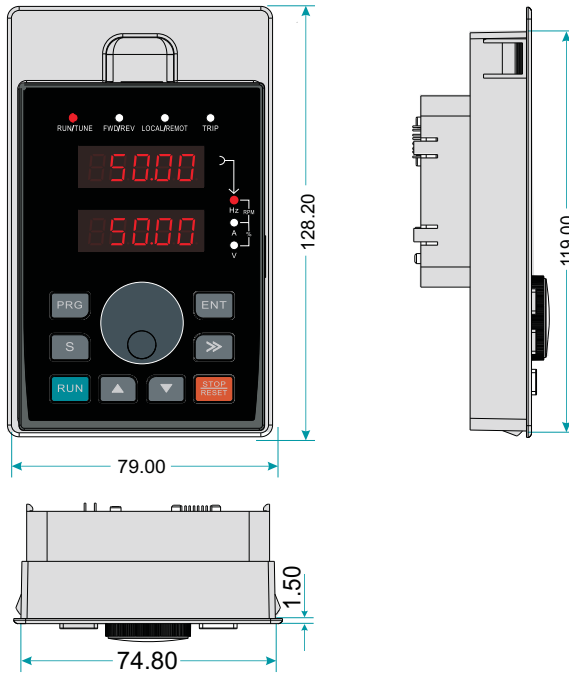

Figure 3-3 Keypad Installation dimensions

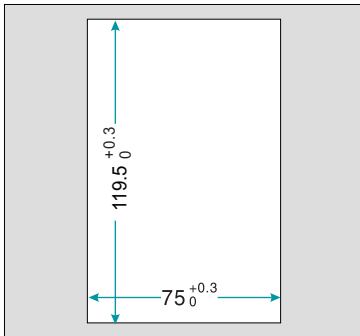

Figure 3-4
Opening dimension diagram
for keypad with base

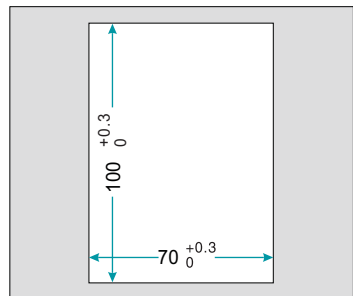



Figure 3-5
Opening dimension diagram
for keypad without base

Chapter 4

Mechanical and Electrical Installation

 **Danger**

- + Only those who are trained and qualified professionals can operate the work described in this chapter. Please operate according to the section of "pay attention to security matters", failure to these may cause personal injury or damage to equipment.
- + Connect the input power lines tightly and permanently. And ground the device with proper techniques.
- + Even when the controller is stopped, dangerous voltage is present at the terminals:
 - Power terminals: R,S,T,P+,P-, PB
 - Motor connection terminals: U,V and W
- + Wait for 10 minutes to let the controller discharge and then begin the installation.
- + Minimum cross-sectional areas of the grounding conductor should be equal to or greater than the power supply cable cross-sectional area.

 **Note**

- + Lift the controller by its base other than the keypad or the cover. The dropping of the main part may cause personal injury.
- + Install the equipment on incombustible objects such as metal, and keep it away from combustible materials. Failure to comply may result in a fire.
- + If more than two controllers are installed in a cabinet, the temperature should be lower than 45°C by means of a cooling fan. Failure it will result in damage to the controller.

4.1 Controller Installation and Operation Environment

4.1.1 Thermal Protection

If installed outdoors, the controller should be installed inside the control box with waterproof function, and the control box there should be vents.

And control box mounted vertically in a well ventilated place, avoid direct sunlight and rainwater. The best installation location can be mounted directly beneath the solar array to prevent the device from overheating and performance degradation. Particularly in places of extreme high temperature, the controller may shut down to protect themselves. For best performance, avoid placing solar panels around any obstacle where there are cast shadows and will reduce the sunlight to these arrays. It is recommended to use a conduit to protect the wire from wildlife and natural weathering and the conduit should be buried underground for extra protection. If there is no use conduit, higher quality outdoor cable should be used.

4.1.2 Installation Location

SP200 PV Pump Controller applies to the site where the ambient temperature ups to 60 degrees. It is recommended to install the controller in the shadow position to avoid overheating fault.

SP200 PV Pump Controller must be installed in the control cabinet. The control cabinet has a such enclosure to avoid direct sunlight and it has functions of rain-proof, dustproof, moisture-proof, anti-animals and so on. Control cabinet should have a sealed bottom plate for mounting wire cable or conduit. Refer to Figure 4-2 below to determine the size of the control cabinet.

4.2 Controller Installation Spacing

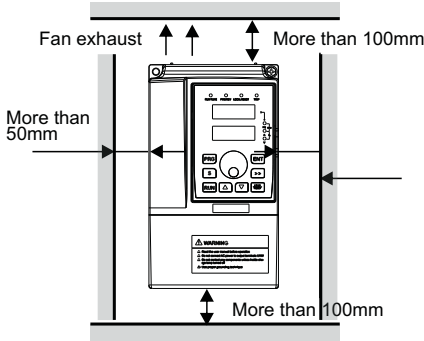

Figure 4-1 Installation distance

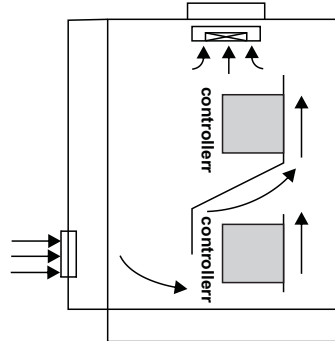

Figure 4-2 Installation of multiple controller

Upper row and lower row installation for two controller, A guide plate should be added between the two controller.

4.3 Install and Remove the Cover

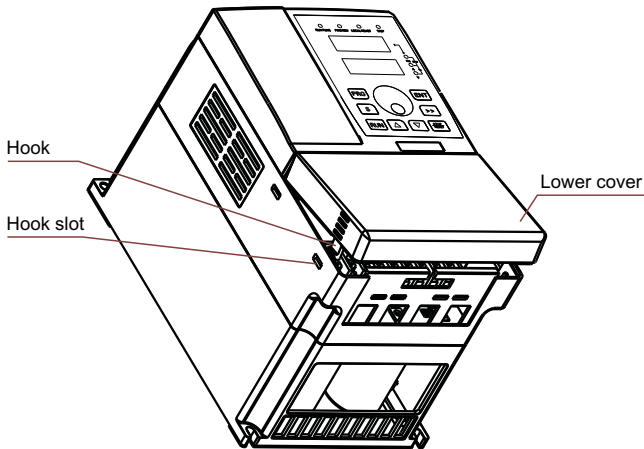

Figure 4-3 Install and remove the plastic lower cover

Note:

Remove the lower cover by pushing the hook of the lower cover inward symmetrically.

4.4 Wiring

Danger

- + Only qualified electricians are allowed to operate on the safe running of the controller.
- + Never carry out any insulation or voltage withstand tests on the cables connecting with the controller.
- + Even if the controller is stopped, dangerous voltage is present at the input power lines, DC circuit terminals and motor terminals. Wait for 10 minutes even when the controller is switched off until the CHARGE light is off before operation.
- + Ground the grounding terminals of the controller with proper techniques.
 - 220V resistor should be 100Ω or less than it
 - 400V resistor should be 10Ω or less than it
 - 690V resistor should be 5Ω or less than itOtherwise there is danger of electric shock and fire.
- + Please ensure the right connection between the power supply wires and motor wires. Connect the power supply to the R,S and T terminals and connect motor wires to U,V and W terminals.
- + Never do wiring or other operation on the controller with wet hands. Otherwise there is danger of electric shock.

Note

- + Verify that the rated voltage of the controller equals to the voltage of the AC power supply.
- + The power wires and motor wires must be permanently fastened and connected.

4.4.1 Typical Wiring Diagram

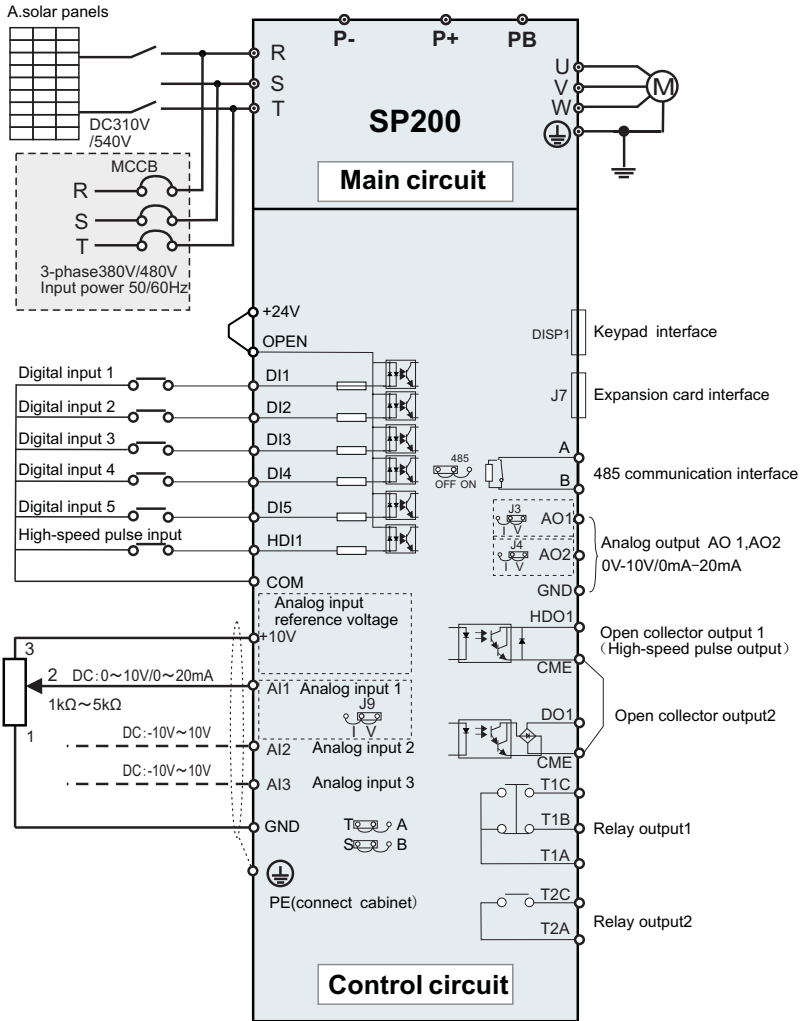

Figure 4-4 Wiring diagram of Control Circuit

4.4.2 Terminal Diagram

4.4.2.1 Main Circuit Terminal

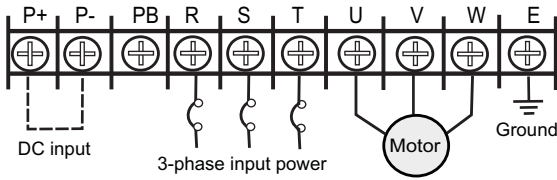

Figure 4-5 Suitable for SP200-4T-22G/30P or less than 22KW machines

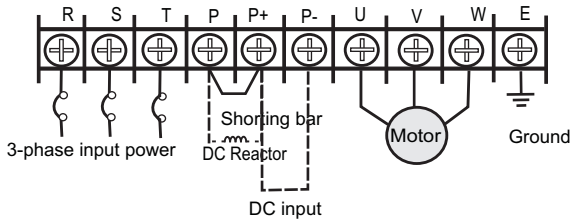

Figure 4-6 Suitable for SP200-4T-30G/37P or more than 37KW machines

The main circuit terminals function description is as follows:

Terminal Name	Function Description
R、S、T	Three-phase power input terminals
P(+)	DC positive bus output terminal
P(-)	DC negative bus output terminal
P(+), P(-)	External braking unit reserve terminals
P(+), PB	External braking resistor reserve terminals
U、V、W	Three-phase AC output terminals
E	Ground terminal

4.4.2.2 Control Circuit Terminal

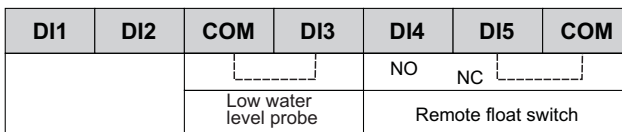



Figure 4-7 Control circuit terminals

4.4.3 Terminal Diagram

For solar pumping system, Dual DC circuit breaker must be installed between PV array and SP200 PV Pump Controller. Connect the cable of the bottom part of dual DC breaker marked as "+" and "-" to SP200 PV Pump Controller wiring terminals "+" and "-".

Note:

R、S、T terminals has the feature of protection against reverse polarity, DC power can connect to R、S、T terminals, and don't need to consider the phase sequence.

 Note	
+	Before connecting the DC wires, follow the steps below to prevent dangerous electrical shock resulting in serious injury or equipment burned down.
+	Ensure the external DC isolation switch is turned off.
+	Ensure that the polarity of the solar array cable must be properly connected with the controller +, - polarity, otherwise may damage the controller.
+	Ensure that the AC power is disconnected (if AC power as an alternate power source, AC and DC power supplies cannot enter the controller at the same time, otherwise it will damage the controller).

4.4.4 Junction box connection

If the solar panels series parallels is too many, then junction box is required to converge the current of the solar array. Junction box is required to install fuse, surge protector, DC switch within it. Fuse and DC switch is helpful to protect from short circuit, surge protector has the effect of lightning protection along DC side. Junction box must be sealed and waterproof.

4.4.5 Ground connection

The ground terminal on the controller (E) is marked as an icon, please connect to ground, if motor fails, proper grounding helps eliminate electric shock risk.

4.4.6 Motor wiring

Connect the 4 wires of the cable to controller's U,V,W,E terminals from the motor. Motor international wiring diagram is as following 9. Check the motor wiring to make sure the installation is correct.

Note:

If the pump reverse, then please reverse any 2 wires.

USA Standard	Black (BLK)	Red (RED)	Yellow (YEL)	Ground (E)
International Standard	Grey (GRY)	Black (BLK)	Brown (BRN)	Ground (E)

4.4.7 Well low water level probe wire (optional)

To avoid the damage of the pump due to pumping in dry condition, well probe can be connected to the control terminals of SP200 PV Pump Controller to detect the well water level, the length of the well probe should not exceeds 50m.If there is no well probe to detect the water level, please keep the 2 terminals of the controller shorted(It is shorted before leaving factory). The well water level aslo can be detected by the built-in water shortage detecting software of the controller, please refer to Chapter F03 Group parameters.

4.4.8 Water tower water level floating ball wiring (optional)

We suggest use one floating ball switch to prevent the overflow of the reservoir, pump will shut down once the reservoir is full.Pum will restart when it is in lower water level. In this way, unnessary pump damage is reduced. SP200 controller enable small termial wire to connect to the remote floating ball switch even if the reservoirs location is far away.

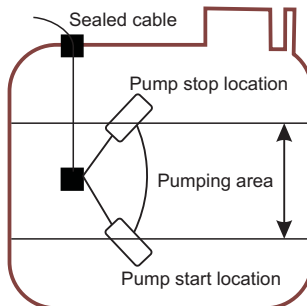

Floating ball switch requirements:

1. terminals wiring is required
2. Minimum wire diameter is 1mm², longest distance is 600m
3. If applied in long distance transmission, shielding wire is must be used, shields near the controller need to be grounded, where near the floating ball switch don't need to be grounded.

If don't apply floating ball switch, then DI5 has to be short with COM.

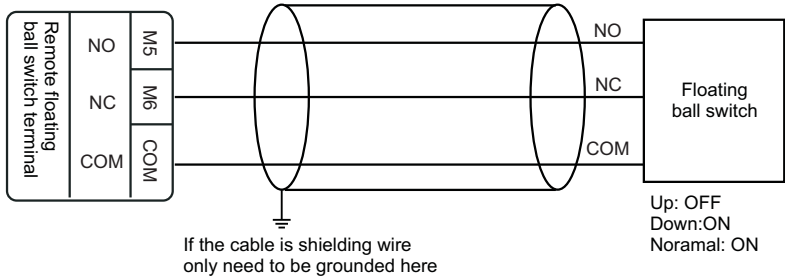

4.4.9 Electrical Conduit application

When the system is installed in outdoor, electrical conduit is required to use to protect the outdoor cable from the influences of weather, human activity, chewing animals. If no application of electrical conduit, please use high quality outdoor cables.



Chapter 5

Operation

5.1 Operation Panel Description

5.1.1 Panel Diagram

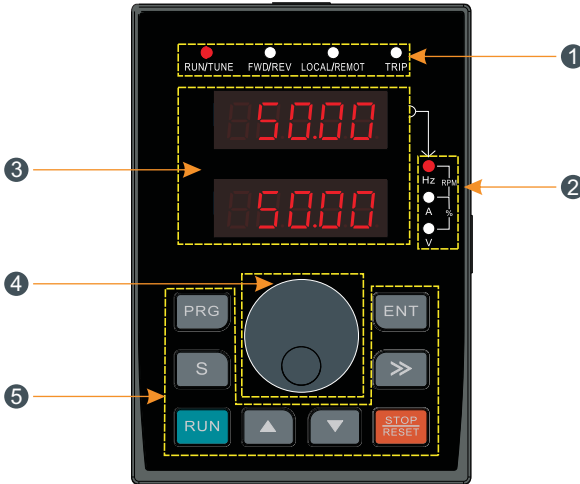
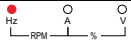
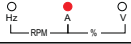
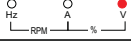

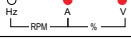









Figure 5-1 SP200 KBA keypad diagram

5.1.2 Button Function Descriptions

No.	Name	Instructions		
①	Status indicator	RUN/TUNE	LED off means that the controller is in the stopping state; LED blinking means the controller is in the parameter autotuning state; LED on means the controller is in the running state.	
		FWD/REV	OFF means the controller is in the forward rotation state ON means the controller is in the reverse rotation state.	
		LOCAL/REMOT	○ LOCAL/REMOT: OFF	Operation panel control
			● LOCAL/REMOT: PN	Terminal control
			◐ LOCAL/REMOT: Flash	Communication control
TRIP	LED for faults LED on when the controller is in the fault state; LED off in normal state LED blinking means the controller is in the pre-alarm state.			

No.	Name	Instructions					
②	Unit indicator	It represents the current display of the Keypad					
			Hz	Frequency unit			
			A	Current unit			
			V	Voltage unit			
			RPM	Speed unit			
			%	Percentage			
③	Code Display Zone	5-figure LED display displays various monitoring data and alarm code such as set frequency and output frequency.					
		Display letter	Corresponding letter	Display letter	Corresponding letter	Display letter	Corresponding letter
		0	0	1	1	2	2
		3	3	4	4	5	5
		6	6	7	7	8	8
		9	9	A	A	b	b
		C	C	d	d	E	E
		F	F	H	H	l	l
		L	L	n	N	n	n
		o	o	P	P	r	r
S	S	t	t	U	U		
u	v	.	.	-	-		
④	Digital potentiometer	When the frequency source A or B is set to 1, the setting of the frequency source is determined by the analog potentiometer input voltage. The maximum output voltage corresponding to the maximum frequency, minimum voltage corresponding to 0 Hz					
⑤	Keypad button zone		Program key	Enter or escape from the first level menu and remove the parameter quickly			
			Entry key	Enter the menu step-by-step confirm parameters			
			Up key	Increase data or function code progressively			
			Down key	Decrease data or function code progressively			
			Right-Shift key	Move right to select the displaying parameter circularly in stopping and running mode. Select the parameter modifying digit during the parameter modification			

No.	Name	Instructions	
5	Keypad button zone		Run key The key is used to operate on the controller in key operation mode
			Stop/Reset This key is used to stop in running state; This key is used to reset all control modes in the fault alarm state..
			S Key F07.01=0 without function F07.01=1 jog running F07.01=2 shift key to change the display state F07.01=3 switch between forward and reverse F07.01=4 clear UP/DOWN setting F07.01=5 coast to stop

5.2 Operation Procedure

5.2.1 Parameter Setting

The controller has three-level menus, they are:

- 1.Group number of function code(first-level menu)
- 2.Tab of function code(second-level menu)
- 3.Set value of function code(third-level menu)

Operation procedure on the operation panel:

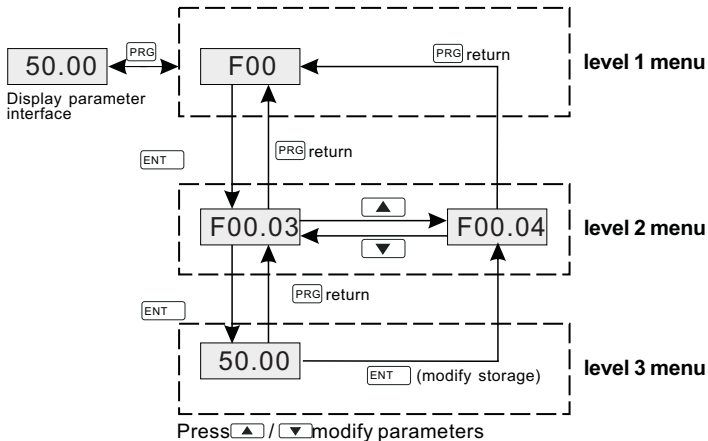

Figure 5-2 Schematic editing diagram

Note:

Press both the "PRG" and the "ENT" key to return to level2 menu from the level3 menu. The difference is: pressing "ENT" will save the set parameters into the control panel, and then return to the level2 menu with shifting to the next function code automatically; while pressing "PRG" will directly return to the level 2 menu without saving the parameters, and keep staying at the current function code.

In Level 3 menu, if the parameter has no blinking digit, it means that the parameter cannot be modified. This may be because:

- a. Such a function code is only readable, such as, controller model, actually detected parameter and running record parameter;
- b. Such a function code cannot be modified in the running state and can only be changed at stop.

Example: Set function code F0C.02 from 10.00Hz to 15Hz.

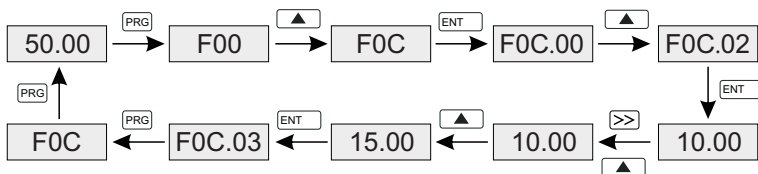

Figure 5-3 Modifying parameters diagram

5.2.2 Password Setting

SP200 series controller provide password protection function to users. Set F07.00 to gain the password and the password protection becomes valid instantly after quitting from the function code editing state. Press "PRG" again to the function code editing state, "0.0.0.0.0" will be displayed. Unless using the correct password, the operators cannot enter it.

Set F07.00 to 0 to cancel password protection function.

The password protection becomes effective instantly after retreating from the function code editing state. Press "PRG" again to the function code editing state, "0.0.0.0.0" will be displayed. Unless using the correct password, the operators cannot enter it.

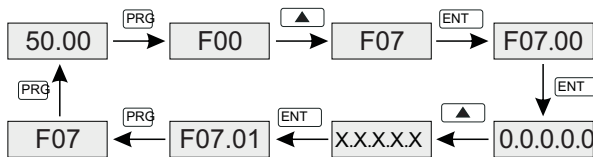

Figure 5-4 Password setting diagram

5.2.3 How to watch the controller state through function codes

SP200 series controller provide groupA02 as the state inspection group. Users can enter into A02 directly to watch the state. Operations procedure as follows:

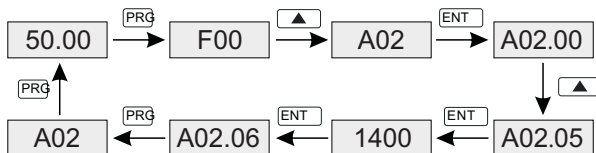

Figure 5-5 Motor speed diagram

5.3 Commissioning Process

- 1: Check and confirm the wiring is correct.
- 2: Using high a megger to test the insulation of the motor and cable if needed.
- 3: Use a multimeter to test whether the open circuit voltage of the DC switch solar modules meet the requirements.
- 4: Close the DC switch to power up the controller

Modify and set the parameters of the motor if needed.

For example, if the motor's rated power is 60Hz, the following parameters need to be modified:

Running frequency upper limit F00.03=60.00 F00.04=60.00

Other related parameters: Motor rated power F02.02, motor rated frequency F02.05, motor rated speed F02.06,

motor rated voltage F02.03, motor rated current F02.04.

Note:

Default motor rated frequency is set to 50Hz.

Slow start to check the direction

Start the motor slowly by pressing the RUN/STOP key, check whether the pump is correct. If the pump run in dry condition, the maximum running time less than 15s. Failure to comply will result in damage to the pump. Turn off the DC switch if water pump rotates in a wrong direction. And swap any two wires of the motor in accordance with the section of the Water Pump or Motor Connection.

After the above steps are completed, you can try to run the system.

Check the water supply capacity when the system work for one hour.

Finish commissioning.

When there is insufficient light, the output power of solar modules is reduced, so the speed of the pump will be very slow until it stops. The controller will try to start once every 120 s, during the trial run, the running indicator light has been lit. When a shadow through the battery array suddenly, the controller will lose track of the input voltage, and the pump will stop working. The controller will try to restart the pump rather than display the fault.

5.4 Panel Displays Parameters in Running State

Display	Name	Description	Unit
H	Running frequency	Current running frequency	Hz
V	Output voltage	Output voltage of controller	V
A	Running current	Actual output current of controller	A
V	Input voltage	DC input voltage	V



Chapter 6

Function Parameter Table

User-defined Parameters

“○”means the set value of the parameter can be modified on stop and running state;

“◎”means the set value of the parameter can not be modified on the running state;

“●”means the value of the parameter is the real detection value which can not be modified.

Function code	Name	Setup range	Default Value	Modification
Group F00 Basic Function Group				
F00.01	Run command channel	0: Keypad run command channel(LED is OFF) 1: Terminal command channel / Keypad STOP disabled(LED is ON) 2: Terminal command channel / Keypad STOP enable(LED is ON) 3:Terminal command channel / Keypad STOP disabled(LED is flashes) 4:Terminal command channel / Keypad STOP enabled(LED is flashes)	1	○
F00.03	Max output frequency	F00.04~600.00Hz	50.00Hz	◎
F00.04	Upper limit frequency	F00.05~F00.03 (Maximum frequency)	50.00Hz	◎
F00.05	Lower limit frequency	0.00Hz~F00.04 (Operating frequency upper limit)	0.00Hz	◎
F00.12	Acc-time 1	0.0~6000.0s	Depend on model	○
F00.13	Dec-time 1	0.0~6000.0s	Depend on model	○
F00.18	Function restore parameter	0 : No operation 1 : Restore the default value 2 : Cancel the fault record	0	◎
Group F01 Startup and stop Control				
F01.08	Stop Mode	0: Decelerate to stop 1: Coast to stop	0	○
F01.18	Select restart after power failure	0: prohibit restart 1: allow restart	0	○
F01.19	Restart waiting time	0.0~6000.0s (F01.18 equal to 1 is valid)	1.0s	○
Group F02 Motor Parameter Group				
F02.02	Rated power of motor 1	0.1~1000.0kW	Depend on model	◎
F02.03	Rated voltage of motor 1	0~1200V	Depend on model	◎
F02.04	Rated current of motor 1	0.8~6000.0A	Depend on model	◎
F02.05	Rated frequency of motor 1	0.01Hz~F00.03 (Maximum)	50.00Hz	○
F02.06	Rated speed of motor1	1~36000rpm	Depend on model	○
Group F03 Solar Water Pump Special Parameters				
F03.07	The lowest operating frequency of water outlet	0~50.00Hz	20.00Hz	◎

Function code	Name	Setup range	Default Value	Modification
F03.08	The lowest operating frequency of water outlet	0~6553.5s	10.0s	⊙
F03.09	Wake detection time 1	0~F3.11s	120.0s	⊙
F03.10	Wake up voltage detected increases in	0~6553.5V	10.0V	⊙
F03.11	Wake detection time 2	0~6553.5s	600.0s	⊙
F03.12	Water shortage underload alarm selection	111	000	⊙
F03.13	Underload detection point	0~100.0%	30%	⊙
F03.14	Underload detection time	0~60.0s	10.0s	⊙
F03.15	Water shortage detection interval	0~60000Min	20.0Min	⊙
Group F05 Input Terminal Group				
F05.01	D11 terminals function selection	0: No function 1: Forward rotation operation 2: Reverse rotation operation 3: Three-wire control operation 6: Coast to stop 7: Fault reset 13: Shift between A setting and B setting 46: Liquid level switch input 47: Floating ball switch input	1	⊙
F05.02	D12 terminals function selection		0	⊙
F05.03	D13 terminals function selection		46	⊙
F05.04	D14 terminals function selection		13	⊙
F05.05	D15 terminals function selection		47	⊙
F05.17	Low water level switch closing delay	0.000~50.000s	1.000s	○
F05.21	Remote floating ball switch closing delay	0.000~50.000s	1.000s	○
Group F07 HMI and Fault Parameters				
F07.00	User's password	0~65535	0	○
F07.02 F07.04	Display parameters for running/stopping state	0x0000~0xFFFF	0x03FF	○
F07.18	Current fault type	See Chapter Seven 7.1 Fault Information and Troubleshooting	----	●
F07.19	The 1 times before fault type		----	●

Function code	Name	Setup range	Default Value	Modification
F07.20	The 2 times before fault type	See Chapter Seven 7.1 Fault Information and Troubleshooting	----	●
F07.21	The 3 times before fault type		----	●
F07.22	The 4 times before fault type		----	●
F07.23	The 5 times before fault type		----	●
F07.24	Running frequency at current fault	----	0.00Hz	●
F07.25	Ramp reference frequency at current fault	----	0.00Hz	●
F07.26	output voltage at the current fault	----	0V	●
F07.27	output current at current fault	----	0.0A	●
F07.28	Bus voltage at current fault	----	0.0V	●
F07.29	The Max. temperature at current fault	----	0.0	●
F07.30	Input terminals state at current fault	----	0	●
F07.31	Output terminals state at current fault	----	0	●
F07.32	Running frequency at previous fault	----	0.00Hz	●
F07.33	Ramp reference frequency at previous fault	----	0.00Hz	●
F07.34	Output voltage at previous fault	----	0V	●
F07.35	The output current at previous fault	----	0.0A	●
F07.36	Bus voltage at previous fault	----	0.0V	●
F07.37	The Max. temperature at previous fault	----	0.0℃	●
F07.38	Input terminals state at previous fault	----	0	●
F07.39	Output terminals state at previous fault	----	0	●
F07.40	Running frequency at previous 2 fault	----	0.0A	●

Function code	Name	Setup range	Default Value	Modification
F07.41	Ramp reference frequency at previous 2 fault	----	0.0V	●
F07.42	Output voltage at previous 2 faults	----	0.0°C	●
F07.43	Output current at previous 2 fault	----	0	●
F07.44	Bus voltage at previous 2 fault	----	0	●
F07.45	The Max. temprature at previous 2 fault	----	0.0°C	●
F07.46	Input terminals state at previous 2 fault	----	0	●
F07.47	Output terminals state at previous 2 fault	----	0	●

Parameter Explanation:

F03.07 The lowest operating frequency of water outlet: the controller real time detects the output power of solar panel and reduces frequency when there is insufficient light. The controller stop and tips E.Sun error if frequency is lower than F03.07 running time and greater than F3.08. Tip into the weak illumination.

F03.09 Wake up detaction time: The controller jugdes voltage every F03.09. Start the controller when voltage is higher than the last time and the enter the weak light bus voltage F3.10. Forced to restart the controller when detection time unable to achieve voltage condition cumulative time F3.11.

F3.14 Water shortage detection time: When applied to deep-well pump and do not use water level detection probe to detect water shortage, water detection can be done via the water detection function of built-in controller. When the Tens change into 1, the function of alarm is valid.

The working principle of software water shortage detection: When the current detection level lower than F03.13% and last the time of F03.14, E.LL water shortage underload fault will appear. This failure can be run automatically after F03.15 delay.

If no shortage of water, the E.LL failure occurs, it may be false positives, just reduces the value of F03.13.

F07.00 User's password: the user can set the 5-digit password, when the setup is completed and confirmed, the password will be valid for one minute.

Warning:

Do not touch any part inside the SP200 PV Pump controller when power on.If you want to use the controller in other areas, please disconnect all the power supply, and wait for 5 minutes before operate.In general, for the selection of SP200 PV pump controller, the controller and the pump power can be matched.However, controller Please enlarge a document if you are driving a submersible pump.It's unnecessary to enlarge while driving a ground pump. Install output reactors if the wiring length is greater than 100 meters.

For example, for a 50-meter deep water well, the 4KW motor matches a 5.5KW controller.



Chapter 7

Troubleshooting

SP200 PV pump controller attempts to drive water pumps to lift water even in severe weather conditions. In order to ensure reliable service life, it must be protected all system components stay away from some factors that could damage the device. When there is a bad situation, if necessary, the controller will reduce the output, continue to water delivery as much as possible, and close in extreme cases. Once the severe situation is slowed down, the controller will automatically try to resume operation.

SP200 PV pump controller possess 20 alarm information and protection functions, once occur abnormal, protective function, controller stop output and fault relay contact, display fault codes on the controller display panel. Using the information given in this chapter, most alarm and fault cause can be identified and corrected. If not, contact with our company.

7.1 Fault Instruction and Solution

No.	Code	Fault	Cause	Solution
1	E.out 1	IGBT U phase protection	<ul style="list-style-type: none"> ◆ The acceleration is too fast . ◆ There is damage to the internal to IGBT of the phase. ◆ The connection of the driving wires and the grounding is not good. 	<ul style="list-style-type: none"> ◆ Increase Acc time. ◆ Change the power unit. ◆ Check the driving wires. ◆ Check if there is strong interference to the external equipment
2	E.out 2	IGBT V phase protection		
3	E.out 3	IGBT W phase protection		
4	E.oc 1	Accelerating overcurrent	<ul style="list-style-type: none"> ◆ The acceleration or deceleration is too fast. ◆ The voltage of the grid is too low. ◆ The power of the controller is too low. ◆ The load transient or abnormal. ◆ The grounding is short circuited or the output is phase loss. ◆ There is strong external interference. 	<ul style="list-style-type: none"> ◆ Increase the Acc time. ◆ Check the input power. ◆ Select the controller with a large power. ◆ Check if the load is short circuited(the grounding short circuited) or the rotation is not smooth. ◆ Check the output configuration. ◆ Check if there is strong interference.
5	E.oc 2	Accelerating overcurrent		
6	E.oc 3	Accelerating overcurrent		
7	E.ou 1	Accelerating overvoltage	<ul style="list-style-type: none"> ◆ The input voltage is abnormal. ◆ There is large energy feedback. 	<ul style="list-style-type: none"> ◆ Check the input power. ◆ Check if the DEC time of the load is too short or the controller starts during the rotation of the motor or it needs to increase the energy consumption components.
8	E.ou 2	Decelerating overvoltage		
9	E.ou 3	Constant overvoltage		
10	E.LU	Bus under-voltage fault	<ul style="list-style-type: none"> ◆ The voltage of the power supply is too low. 	<ul style="list-style-type: none"> ◆ Check the input power of the supply line.
11	E. ol 1	Motor overload	<ul style="list-style-type: none"> ◆ The voltage of the power supply is too low. 	<ul style="list-style-type: none"> ◆ Check the input power of the supply line.
12	E. ol 2	Inverter overload	<ul style="list-style-type: none"> ◆ The acceleration is too fast. ◆ Reset the rotating motor. ◆The voltage of the power supply is too low. ◆ The load is too heavy. 	<ul style="list-style-type: none"> ◆ Increase the Acc time. ◆ Avoid the restarting after stopping. ◆ Check the power of the supply line, ◆ Select an controller with bigger power, ◆ Select a proper motor.
13	E.SPI	Input phase loss	<ul style="list-style-type: none"> ◆ Phase loss or fluctuation of input R,S,T. 	<ul style="list-style-type: none"> ◆ Check input power
14	E.SPO	Output phase loss	<ul style="list-style-type: none"> ◆ U,V,W phase loss input (or serious asymmetrical three phase of the load) 	<ul style="list-style-type: none"> ◆ Check input power
15	E,OH1	Rectifying module overheated	<ul style="list-style-type: none"> ◆ Air duct jam or fan damage. 	<ul style="list-style-type: none"> ◆ Check input power

No.	Code	Fault	Cause	Solution
16	E.OH2	IGBT overheated	<ul style="list-style-type: none"> ◆ Ambient temperature is too high. ◆ The time of overload running is too long 	<ul style="list-style-type: none"> ◆ Check input power
17	E.EF	External fault	<ul style="list-style-type: none"> ◆ SI external fault input terminals action. 	<ul style="list-style-type: none"> ◆ Check input power
18	E.CF	485 communication fault	<ul style="list-style-type: none"> ◆ The baud rate setting is incorrect. ◆ Fault occurs to the communication wiring. ◆ The communication address is wrong. ◆ There is strong interference to the communication. 	<ul style="list-style-type: none"> ◆ Set proper baud rate. ◆ Check the communication connection distribution. ◆ Set proper communication address. ◆ Change or replace the connection distribution or improve the anti-interference capability.
19	E.LCE	Current-detecting fault	<ul style="list-style-type: none"> ◆ The connection of the control board is not good. ◆ Hoare components is broken ◆ The modifying circuit is abnormal. 	<ul style="list-style-type: none"> ◆ Check the connector and repatch. ◆ Change the hoare. ◆ Change the main panel.
20	E.TUE	Motor-autotuning fault	<ul style="list-style-type: none"> ◆ The motor capacity does not comply with the controller capability. ◆ The rated parameter of the motor does not set correctly. ◆ The offset between the parameters from autotune and the standard parameter is huge. ◆Autotune overtime. 	<ul style="list-style-type: none"> ◆ Check the connector and repatch. ◆ Change the hoare. ◆ Change the main panel.
19	E.LCE	Current-detecting fault	<ul style="list-style-type: none"> ◆ The connection of the control board is not good. ◆ Hoare components is broken ◆ The modifying circuit is abnormal. 	<ul style="list-style-type: none"> ◆ Check the connector and repatch. ◆ Change the hoare. ◆ Change the main panel.
20	E.TUE	Motor-autotuning fault	<ul style="list-style-type: none"> ◆ The motor capacity does not comply with the controller capability. ◆ The rated parameter of the motor does not set correctly. ◆ The offset between the parameters from autotune and the standard parameter is huge. ◆ Autotune overtime. 	<ul style="list-style-type: none"> ◆ Change the controller mode. ◆ Set the rated parameter according to the motor name plate. ◆ Empty the motor load and reidentify. ◆ Check the motor connection and set the parameter.
21	E.EEP	EEPROM operation fault	<ul style="list-style-type: none"> ◆ Error of controlling the write and read of the parameters. ◆ Damage to EEPROM. 	<ul style="list-style-type: none"> ◆ Press STOP/RESET to reset. ◆ Change the main control panel.
22	E.PID	PID feedback outline fault	<ul style="list-style-type: none"> ◆ PID feedback offline. ◆ PID feedback source disappear. 	<ul style="list-style-type: none"> ◆ Check the PID feedback signal. ◆ Check the PID feedback source.
23	E.BRE	Braking circuit fault	<ul style="list-style-type: none"> ◆ Braking circuit fault or damage to the braking popes. ◆ The external braking resistor is not sufficient. 	<ul style="list-style-type: none"> ◆ Check the braking unit and change new braking pipe. ◆ Increase the braking resistor.
24	E.End	Running time arrival	<ul style="list-style-type: none"> ◆ The actual running time of the AC drive is above the internal setting running time. 	<ul style="list-style-type: none"> ◆ Ask for the supplier and adjust the setting running time.

No.	Code	Fault	Cause	Solution
25	E.oL3	Electronic overload fault	<ul style="list-style-type: none"> ◆ The controller will report the over-load pre-alarm according to the set value. 	<ul style="list-style-type: none"> ◆ Check the load and the overload pre-alarm point.
26	E.PCE	Keypad communication fault	<ul style="list-style-type: none"> ◆ The connection of the Keypad wires is not good or broken. ◆ The Keypad wire is too long and affected by strong interference. ◆ There is circuit fault on the communication of the Keypad and main board 	<ul style="list-style-type: none"> ◆ Check the Keypad wires and ensure whether there is mistake. ◆ Check the environment and avoid the interference source. ◆ Change the hardware and ask for service.
27	E.UPE	Parameters uploading fault	<ul style="list-style-type: none"> ◆ The connection of the Keypad wires is not good or broken. ◆ The Keypad wire is too long and affected by strong interference. ◆ Communication fault. 	<ul style="list-style-type: none"> ◆ Check the Keypad wires and ensure whether there is mistake. ◆ Change the hardware and ask for service. ◆ Change the hardware and ask for service.
28	E.DnE	Parameters downloading fault	<ul style="list-style-type: none"> ◆ The connection of the Keypad wires is not good or broken. ◆ The Keypad wire is too long and affected by strong interference. ◆ There is mistake on the data storage of the Keypad. 	<ul style="list-style-type: none"> ◆ Check the Keypad wires and ensure whether there is mistake. ◆ Change the hardware and ask for service. ◆ Repack-up the data in the keyboard
29	E.ErH1	Grounding shortcut fault 1	<ul style="list-style-type: none"> ◆ The output of the controller is short circuited with the ground. ◆ There is fault in the current detection circuit. 	<ul style="list-style-type: none"> ◆ The output of the controller is short circuited with the ground. ◆ There is fault in the current detection circuit.
30	E.ErH2	Grounding shortcut fault 2	<ul style="list-style-type: none"> ◆ The output of the controller is short circuited with the ground. ◆ There is fault in the current detection circuit. 	<ul style="list-style-type: none"> ◆ The output of the controller is short circuited with the ground. ◆ There is fault in the current detection circuit.
31	E.dEu	Speed deviation fault	<ul style="list-style-type: none"> ◆ The load is too heavy or stalled. 	<ul style="list-style-type: none"> ◆ Check the load and ensure it is normal. Increase the detection time. ◆ Check whether the control parameters are normal.
32	E.STo	Maladjustment fault	<ul style="list-style-type: none"> ◆ The control parameters of the synchronous motors not set properly. ◆ The autoturn parameter is not right. ◆ The controller is not connected to the motor. 	<ul style="list-style-type: none"> ◆ Check the load and ensure it is normal. ◆ Check whether the control parameter is set properly or not. ◆ Increase the maladjustment detection time.
33	E.Esd1	Encoder disconnect fault	<ul style="list-style-type: none"> ◆ Closed loop control, encoder signal disconnect. ◆ Encoder damage. 	<ul style="list-style-type: none"> ◆ Check encoder connection, reconnected circuit. ◆ Check whether the encoder is input or output.

No.	Code	Fault	Cause	Solution
34	E.Ecd2	Encoder reverse fault	<ul style="list-style-type: none"> ◆ Closed loop control, encoder disconnection, damage or connect fault. 	<ul style="list-style-type: none"> ◆ Check encoder connection, adjust wiring.
35	E.Ptc	Motor overheated fault	<ul style="list-style-type: none"> ◆ Motor long-term overload running or abnormal, temperature detect resistance. ◆ Motor overheated improper protection point. 	<ul style="list-style-type: none"> ◆ Check the motor and maintain. ◆ Check whether normal the temperature sensor. ◆ Reset the motor overheated protection point.
36	E.LL	Electronic underload fault	<ul style="list-style-type: none"> ◆ The controller will report the underload pre-alarm according to the set value. 	<ul style="list-style-type: none"> ◆ Check the load and the underload pre-alarm point.
37	E.dp	Dp Communication Fault	<ul style="list-style-type: none"> ◆ Improper setting of baud rate, ◆ Communication line fault, ◆ Wrong communication address, ◆ Strong interference towards communication 	<ul style="list-style-type: none"> ◆ Set proper baud rate. ◆ check the interface line of communication. ◆ set correct communication address. ◆ change or replace the line to improve the ability to resist the interference.
38	E.cAN	Can Communication fault	<ul style="list-style-type: none"> ◆ Improper setting of baud rate, ◆ Communication line fault, ◆ Wrong communication address, ◆ Strong interference towards communication 	<ul style="list-style-type: none"> ◆ Set proper baud rate. ◆ check the interface line of communication. ◆ set correct communication address. ◆ change or replace the line to improve the ability to resist the interference.
39	E.Sun	Water failure		

7.2 Common Faults and Solutions

Controller may have following faults or malfunctions during operation, please refer to the following solutions:

1. No display after power on:

- 1) Inspect whether the voltage of power supply is the same as the controller rated voltage or not with multi-meter. If the power supply has problem, inspect and solve it.
- 2) Inspect whether the three-phase rectify bridge is in good condition or not. If the rectification bridge is burst out, ask for support.
- 3) Check the CHARGE light. If the light is off, the fault is mainly in the rectify bridge or the buffer resistor. If the light is on, the fault may be lies in the switching power supply.Please ask for support.

2. Power on operation panel display “CE”:

Inspect whether the keypad and master control board wiring is normal once they appear fault.

3. Power supply air switch trips off when power on:

- 1) Inspect whether the ground terminal E is grounded. Please solve the problem.
- 2) Inspect whether the input power supply is grounded or short circuit. Please solve the problem.
- 3) Inspect whether the rectify bridge has been burnt or not. If it is damaged, ask for support.

4. Pump doesn't move after controller running:

The main problem of the newly installed system is that the connection non- standard and the controller terminal line falls off so that lead to the pump can't running.

Although the controller keypad RUN indicate ON and exist output voltage, the solar array without sufficient output power to start up pump and controller will try to each 120s to start up pump. Pump does not run such as the following reasons:

- 1) Without adequate lighting, controller input power insufficient lead to the pump does not work.
- 2) Motor wiring error will lead to pump reversal, please configure correctly.
- 3) Motor shaft vibration can't rotate, the reason might be motor configuration is wrong, please check the motor configure.
- 4) Pump and pipe may be clogged with silt and debris, causing the pump abnormal running.

7.3 Controller Overcurrent, Overload Fault (OC1/2/3/OL1/2)

Controller overload and overcurrent faults may occur for the following reasons:

1. Pump or pipe is blocked, the pump running current increase, causing the controller to be protected, please check the pump.
2. Pump running current increase due to pump wire too long, causing the controller to be protected, please enlarge a document using the controller.

Chapter 8

Maintenance

Danger

- ✦ Maintenance must be performed according to designated maintenance methods.
- ✦ Maintenance, inspection and replacement of parts must be performed only by certified person.
- ✦ After turning off the main circuit power supply, wait for 10 minutes before maintenance or inspection.
- ✦ Do not direct touch the components or devices of PCB board. Otherwise controller can be damaged by electrostatic.
- ✦ After maintenance, all screws must be tightened.

8.1 Controller

8.1.1 Controller

Controller belong to electric product, when operate, it will heating. Therefore, it is necessary for daily and periodic maintenance and clear.

Routine cleaning involves:

1. Keep the controller clean all the time.
2. Remove the dust, especially metal powder on the surface of the controller, to prevent the dust from entering the controller.
3. Clear the oil stain on the cooling fan of the controller.

8.1.2 Periodic Maintenance

In order to prevent the fault of controller to make it operate in high-performance for a long time, user must inspect the controller periodically (within half year). The following table indicates the inspection content.

Checking Item	Content	Solution
Screws of the external terminals	Check if the screw is loose or not.	Tighten up
PCB board	Dust and dirtiness	Clear the sundries with dry compressed air.
The fan	Check if the accumulative time of abnormal noise and vibration exceeds 20,000 hours.	1: Clear the sundries 2: Change the fan
Electrolytic capacitance	Check if the color has changed and if it smelly	Change the electrolytic capacitance
Heat sink	Dust and dirtiness	Clear the sundries with dry compressed air.
Power components	Dust and dirtiness	Clear the sundries with dry compressed air.

Note:

Before measuring the insulating resistance with megameter (500VDC megameter recommended), disconnected the main circuit from the controller. Do not use the insulating resistance meter to test the insulation of the control circuit. The high voltage test need not be performed again because it has been completed before delivery.

8.1.3 Replacement of Vulnerable Components

The vulnerable components of the controller are cooling fan and filter electrolytic capacitor. Their service life is related to the operating environment and maintenance status. Generally, the service life is shown as follows:

Component	Service life
Fan	2~3 years
Electrolytic capacitor	4~5 years

Note:

The standard replace time is the following using time, users can confirm the replace use age comply to the running time.

- ◆ Environment temperature: The annual average temperature is about 30 degrees.
- ◆ Overload ratio: Under 80%.
- ◆ Running ratio: Under 20 hours per day.

1. Cooling fan

- ◆ Possible damage reason: Bearing worn, blade aging.
- ◆ Judging criteria: Whether there are crack on the blade and abnormal vibration noise upon startup.

2. Filter electrolytic capacitor

- ◆ Possible damage reason: Input power supply, high ambient temperature, frequency load jumping, electrolytic aging.
- ◆ Judging criteria: Whether there is liquid leakage and safe valve has projected. Measure the static capacitance and insulating resistance.

8.1.4 Storage of the controller

For storage of the controller, pay attention to the following two aspects.

1. Pack the controller with the original packing box provided by Our company.
2. Long-term storage degrades the electrolytic capacitor. Thus, the controller must be energized once every 2 years, each time lasting at least 5 hours. The input voltage must be increased slowly to the rated value with the regulator.

8.1.5 Warranty Agreement

1. Free warranty only applies to the controller itself.
2. Our company provides 18-month warranty (starting from the leave-factory date as indicated on the bar code) for the failure or damage under normal use conditions. If the equipment has been used for over 18 months, reasonable repair expenses will be charged.

3. Reasonable repair expense will be charged for the damages due to the following causes:
 - a. Improper operation without following the instructions.
 - b. Fire, flood or abnormal voltage.
 - c. Using the controller for non-recommended function.
4. The maintenance fee is charged according to Our company's uniform standard. If there is an agreement, the agreement prevails.

8.2 Pump

Motor is permanently sealed and does not require maintenance. Instead of the pump head is mechanical device, which will be abrasion by the sand after use for a long time, so it need to test the pump performance regularly. If the pump is less than the normal value that need to be replaced.

8.3 Solar Array

Regularly check if the mounting bolt is loose and clean the solar module surface.

8.4 Electric Wire and Cable

Regularly check if the source and earth wire is connected and corroded.



Chapter 9

Spare AC Power Use

In order to ensure continuous supply water, user can manual switch the SP200 PV pumping system to the standby AC power supply when the light is insufficient or rainy weather. When switching, DC and AC power interlock need to be ensured. Alternate AC power not only can be local network but also can be diesel generator (Please refer to 2.4.3 input and output parameter table).

Note:

At any moment, there is only one kind of power can be input, otherwise, it may lead to contr-oller failure.

Three phase 380VAC Alternate AC power supply, for example, wiring diagram such as following:

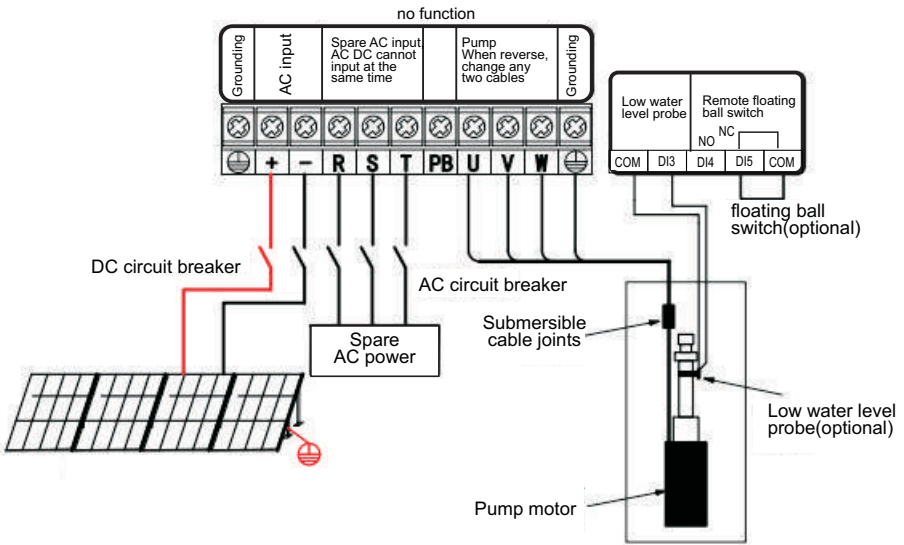

If pump motor voltage is three phase 220-240VAC, the single phase 20VAC alternate power supply L/N wire need to connect to the controller main terminal R/T.

Warranty Agreement

- ① The warranty period of the product is 18 months (refer to the bar code on the equipment body). During the warranty period , if the product fails or damaged under the condition of normal use by following the instruction, we will be responsible for free maintenance.
- ② Within the warranty period , maintenance will be charged for the damages caused by the following reasons :
 - ✧ The damage caused by improper use or repair/modification without prior permission.
 - ✧ The damage caused by fire , flood , abnormal voltage , other natural disasters and second disaster.
 - ✧ The hardware damage caused by artificial falling or transportation after purchase.
 - ✧ The damage caused by the improper operation.
 - ✧ The damage or failure caused by the trouble out of the equipment (e.g. : External device)
- ③ If there is any failure or damage to the product, please fill in the information of the Product Warranty Card in details correctly.
- ④ The maintenance fee is charged according to the newly adjusted Maintenance Price List of our company .
- ⑤ In general , the warranty card will not be re-issued. Please keep the card and present it to the maintenance personnel when asking for maintenance .
- ⑥ If there is any problem during the service , please contact the agent of our company or our company directly .

SHENZHEN SINOVO ELECTRIC TECHNOLOGIES CO.,LTD.
Service Department

**Add: 5th Floor, No. D Building , Huafeng International Robot Industry Park,
Xixiang Street , Hangcheng Road, Baoan District, Shenzhen City**

Tel : 0755-29784870

Sell Service Center : 0755-29784875

Fax : 0755-29784969

P.C. : 518000

SHENZHEN SINOVO ELECTRIC TECHNOLOGIES CO.,LTD.

Product Warranty Card

Customer information	Add. of corporation :	
	Name of corporation :	Contact person :
	P.C. :	Tel. :
Product information	Product model :	
	Body bar code :	
	Name of agent :	
Failure information	(maintenance time and content) :	
	Maintenance personnel :	